

MAINTENANCE OF A PLATFORM CAR
SUPERSTRUCTURE
INSTRUCTIONS ON INSTALLATION AND USE

LIGHT PLATFORM CAR TT
UP TO 3.5T
CANVAS STRUCTURE

Contents:

1 Types of platform car canvas superstructures	2
With non-lifting roof.....	2
With lifting roof	2
Instructions on use and conditions of operation	2
Superstructure description	2
Maintenance of the platform car superstructure	3
3 Parts for platform car canvas superstructures	4
Aluminium platform components	5
Frame profile for vehicles up to 3.5t	6
Cross profile to the frame profile	6
Options of use of the longitudinal profiles	7
Assembly corners for frame profile 70mm	8
Platform accessories	9
Components for the canvas structure	11
Al profiles of the columns	12
Corner columns stiffeners	12
Lugs for Al columns	13
Central columns and their components.....	13
Sidewall profiles, under-canvas profiles	15
Hinge TIR	16
Sidewall closures	17
Tube roof assembly sets, non-lifting	18
Tube roof	19
Lifting roof parts	20
Parts for side folding	22
Gate parts	24
Accessories	25
4 Assembly of a platform car canvas structure	27
Installation of the platform	27
Installation of front and rear columns (non-lifting) to corners 80x40 (Type 0433 27x.xxx)	34
Installation of lifting columns to corners 80x40	35
Installation of the central column	36
Installation of the front face	37
Installation of sidewalls and pockets for lathes	38
Installation of the rear face and lathes	40
Installation of roof parts.....	41
Installation of side folding	42
Installation of the gate	43

1 Types of platform car canvas superstructures

1.1. With non-lifting roof

- With side folding
- Without side folding

1.2. With lifting roof

- With side folding
- Without side folding

2 Instructions on use and conditions of operation

2.1. Superstructure description

The platform car superstructure is designed for road traffic vehicles. Its construction and use shall follow the applicable regulations, particularly Act no. 56/2001 Coll. on conditions of operation of vehicles on roads, and Decree no. 341/2014 Coll. of approving of technical capability and technical conditions of operation of vehicles on roads. It can only be operated by persons knowing these regulations and instructed properly about operation of a platform car superstructure.

Platform car superstructures are designed particularly for transport of piece loads, above all piece load, on the platform car loading area. The load shall be laid out on the loading area evenly to prevent overloading of any part of the loading area, and secured so that it cannot be displaced or overturned during its transport. Therefore the superstructure is equipped with anchoring lugs in the aluminium frame of the platform car for fixing of the load. The load is fixed to these anchoring lugs by clamping straps.

Location and number of the anchoring lugs is determined by the superstructure manufacturer, based on the applicable regulations.

Attention!

Weight of the load shall not exceed the permitted loading specified in the vehicle technical certificate. Driving with non-anchored load may cause damage to the superstructure.

The superstructure is equipped with tiltable sidewalls and tiltable rear face to facilitate loading and unloading. The sidewalls are fixed to the corner or central columns by closures. A check of proper closing of the sidewalls and rear face shall always be made before the journey, to prevent any spontaneous opening of the sidewalls during the journey.

Attention!

Drive with sidewalls or rear face tilted down is forbidden. In case it is necessary to drive with sidewalls or rear face tilted down, it is possible if these are open and slid out of their hinges.

In case of incorrect use of the structure the supplier of parts for platform car superstructures cannot be responsible for any possible damages caused by non-observance of the applicable regulations.

Any warranty for this superstructure becomes void in case of incorrect use of the platform car superstructure.

2 2. Maintenance of the platform car superstructure

The platform car superstructure does not require any special maintenance. It is important to keep the superstructure clean, wash it by pressure water, particularly during winter season, when chemicals are used on roads and that may impair functionality of the sidewall hinges and locks and cause corrosion of the galvanised components if these are left dirty for a long time.

Attention!

*Hinges of the sidewalls and their closures shall be treated regularly using preservative lubricants.
Closures of the central columns shall be treated regularly using preservative lubricants.*

Attention!

Due to the fact that all bolted joints of the aluminium platform (clamps PALCOM) are secured by an adhesive against any spontaneous release of the bolts, it is forbidden to retighten these joints during operation. This might cause release of these joints leading to damage of the supporting parts of the superstructure.

In case of a fault on the supporting parts contact please an authorised service centre or a company that assembled the platform car superstructure. The particular company can repair the superstructure professionally using properly specified spare parts.

Maintenance of the platform car superstructure

The platform car superstructure consists of a set of components prepared always for the given dimension and design, according to the customer's requirement. The aluminium platform consists of auxiliary profiles, crosspieces and frame profiles connected together by special clamps. The frame profiles are connected in corners and possibly also under central column using special corner and central elements. Such assembled platform forms the platform car structure. This structure consists of corner and central columns that are also supporting components of the roof structure. Sidewalls of aluminium profiles thick 25mm with closures are fixed to the frame using hinges that enable tilting of the sidewalls and face down and their detachment. The sidewalls and rear face are manufactured mostly of one-piece profiles 400mm high. Upon customer's requirements, we can also deliver sidewalls with different heights, e.g. 500 or 600mm. The front face can be delivered with different heights, according to the customer's requirement. Al profiles 100x25mm as supports of the canvas are used on sides of the superstructure, between the columns. The number of profiles can be chosen by the customer.

The roof structure consists of a frame assembled of aluminium profiles 60x30x2mm, fixed to aluminium corner columns using corner assembly sets. Steel brackets with rubber inserts are riveted to this frame; aluminium tubes \varnothing 35 mm for supporting of the roof canvas are located in these brackets. The canvas is not included in the delivery of the company TRANS-TECHNIK.

3 Parts for platform car canvas superstructures

L_n = Superstructure length max. **5,500mm**

\check{S}_n = Superstructure outer width

V_n = Superstructure height max. **2,460mm**

B_{nv} = Side loading height max. **2,400 mm** – applicable for fixed AL columns

B_{nv} = Side loading height max. **2,300 mm** – applicable for AL lifting columns in non-lifted position

Lift of the column $H_v + 200\text{mm}$ or 300mm

L_{sl} = Column length

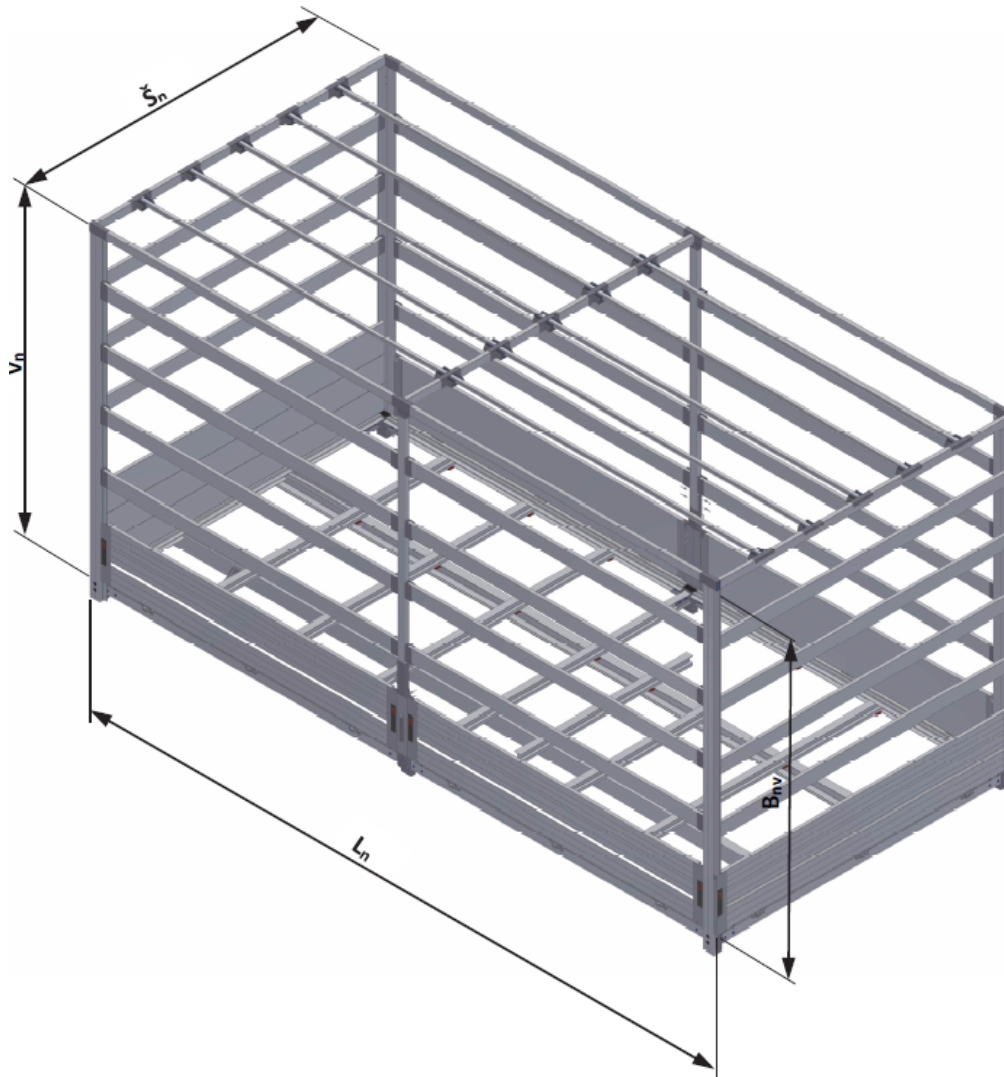

L_n = Platform length + 35mm

\check{S}_n = Platform width + 2x35mm

V_n = $B_{nv} + 60\text{mm}$

V_n = $B_{nv} + 150\text{mm}$

3 1. Aluminium platform components

Consisting of longitudinal and cross components, frame profiles, fixing Palcom clamps, steel corners and stiffeners.

L_p = Platform length

\check{S}_p = Platform width

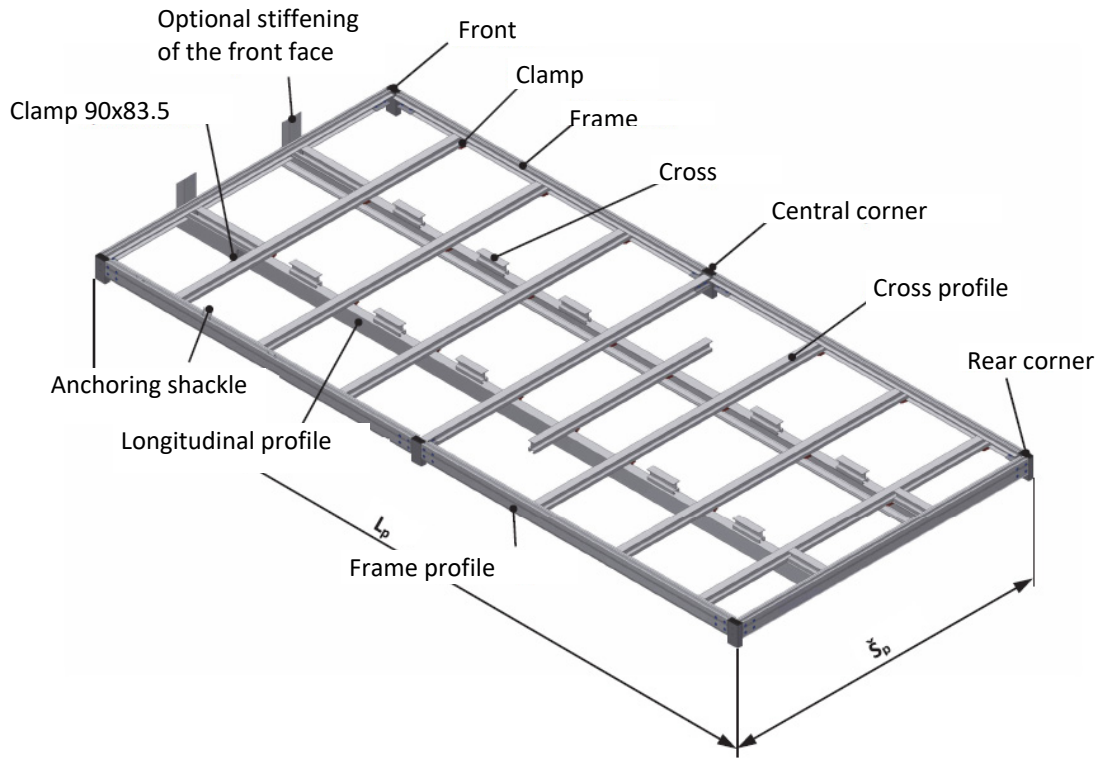

3.1.1. Frame profile for vehicles up to 3.5t

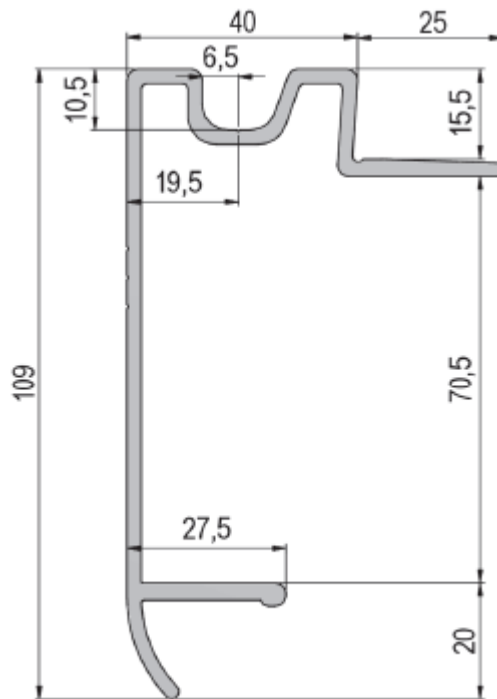

TT-no.	Description	Material / surface	Weight kg/m
0431 016.000	Frame profile with groove 70mm	Aluminium, natural	1.64
0432 016.000	Frame profile with groove 70mm	Anodized aluminium	

3.1.2. Cross profile to the frame profile

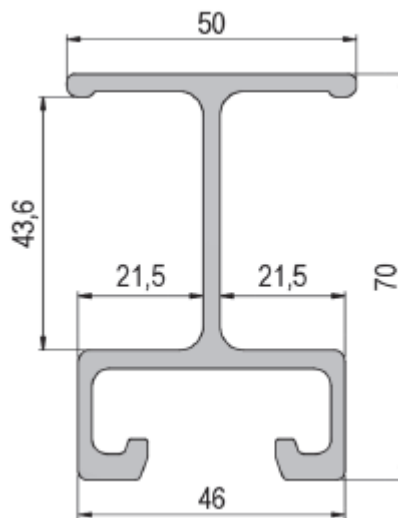

TT-no.	Description	Material / surface	Weight kg/m
0431 015.000	Cross profile 70mm	Aluminium, natural	1.73

3.1.3. Options of use of the longitudinal profiles

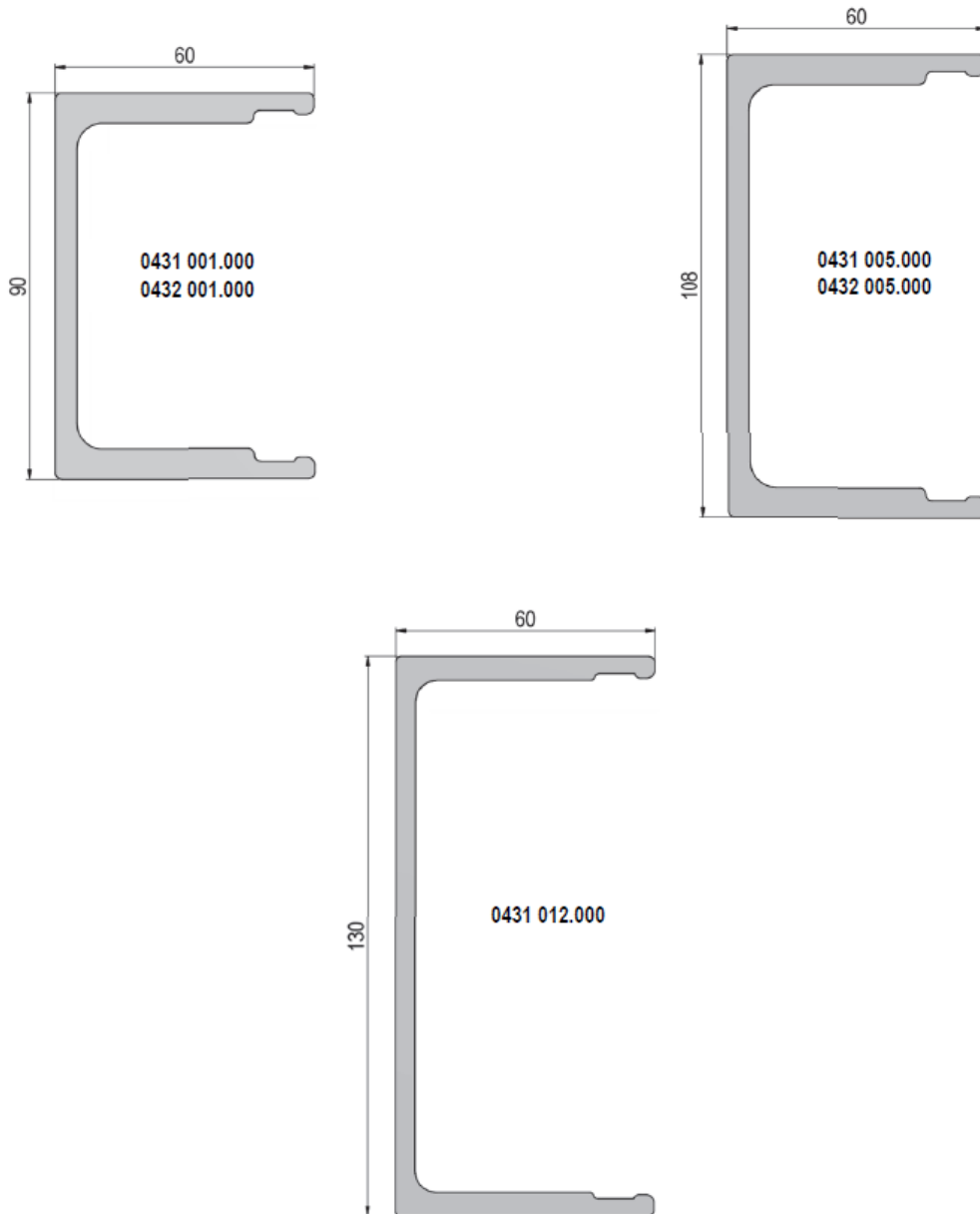

TT-no.	Description	Material / surface	Weight kg/m
0431 001.000	Auxiliary Al profile 90mm	Aluminium, natural	3.13
0432 001.000	Auxiliary Al profile 90mm	Anodized aluminium	
0431 005.000	Auxiliary Al profile 108mm	Aluminium, natural	3.37
0432 005.000	Auxiliary Al profile 108mm	Anodized aluminium	
0431 012.000	Auxiliary Al profile 130mm	Aluminium, natural	3.20
0432 012.000	Auxiliary Al profile 130mm	Anodized aluminium	

3.1.4. Assembly corners for frame profile 70mm

Recommended for vehicles with carrying capacity up to 3,5t

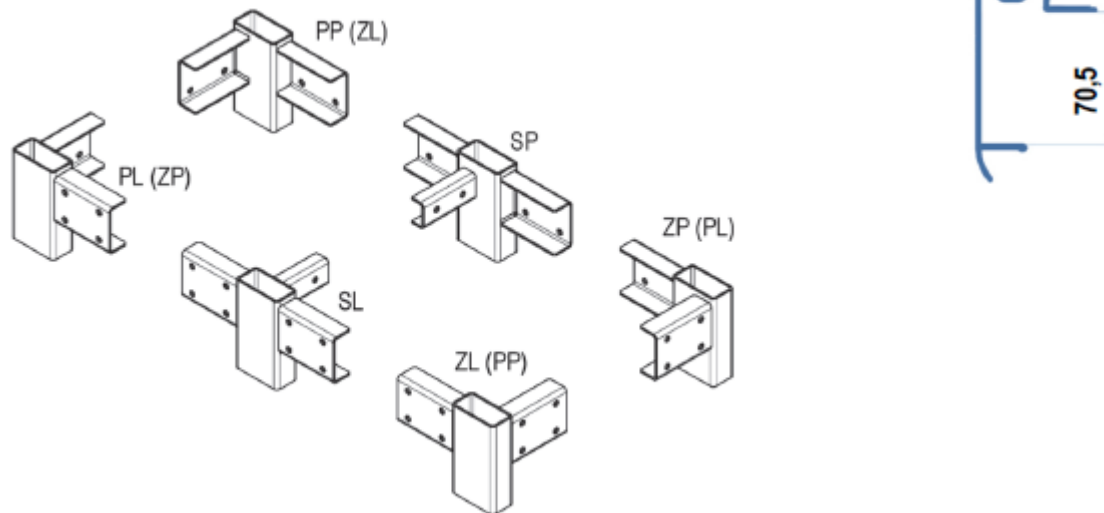

TT-no.	Description	Surface	Weight kg/pc
0433 270.000	Corner FR (RL) 80x40/70, complete	galvanised	1.4
0433 271.000	Corner FL (RR) 80x40/70, complete	galvanised	1.4
0433 274.000	Corner CR 80x40/70, complete	galvanised	1.6
0433 275.000	Corner CL 80x40/70, complete	galvanised	1.6
0433 070.000	Corner FR (RL) 100x40/70, complete	galvanised	1.53
0433 071.000	Corner FL (RR) 100x40/70, complete	galvanised	1.53
0433 074.000	Corner CR 100x40/70, complete	galvanised	1.72
0433 075.000	Corner CL 100x40/70, complete	galvanised	1.72

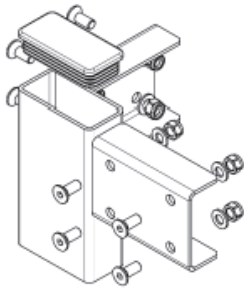

PL (ZP)
0433 271.000
0433 071.000

Description	Qty
FL (RR) corner	1
Bolt M8x20, sunk head, 8.8	8
Nut M8, self-locking	8
Spring washer 8.4	8
Plastic blind cap	1

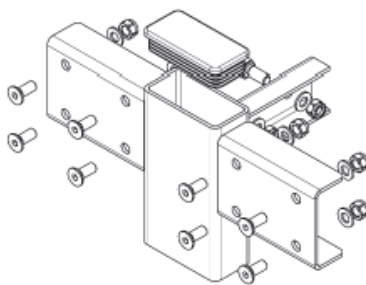

SL
0433 275.000
0433 075.000

Description	Qty
Central CL corner	1
Bolt M8x20, sunk head, 8.8	8
Bolt M8x20, hex. head, 8.8	2
Nut M8, self-locking	10
Spring washer 8.4	10
Plastic blind cap	1

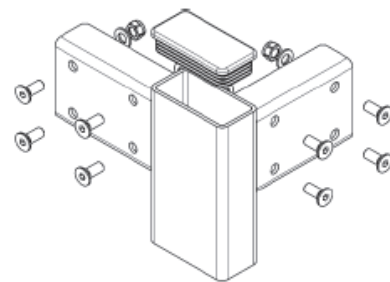

PP (ZL)
0433 270.000
0433 071.000

Description	Qty
RL (FR) corner	1
Bolt M8x20, sunk head, 8.8	8
Nut M8, self-locking	8
Spring washer 8.4	8
Plastic blind cap	1

TT-no.	Description	Material / surface	Weight kg
0433 079.000	Central brace for frame 70mm, complete	Galvanised steel	0.8

Use with central columns instead of central connecting parts

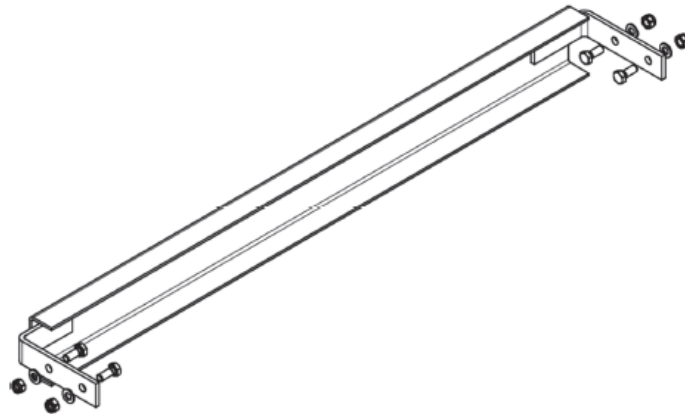

3.1.5. Platform accessories

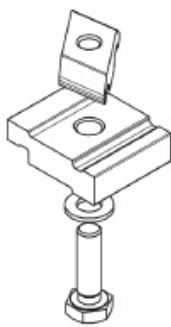

0433 030.000



0433 033.000

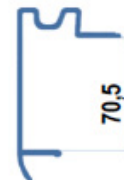

TT-no.	Description	Material / surface	Weight kg/m
0433 030.000	Clamp Palcom L=44mm, complete	Aluminium, natural	0.13
0433 033.000	Clamp Palcom upper + bolt M10x25, washer	Aluminium, natural	0.05

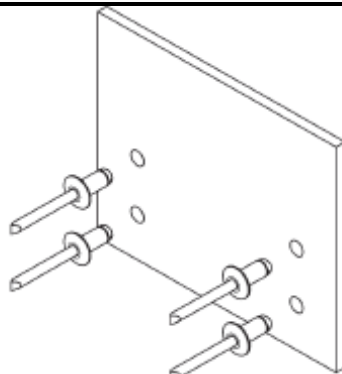

TT-no.	Description	Material / surface	Weight kg
0433 101.000	Front face stop 120x100, thickness 4.5	Aluminium, natural	0.15

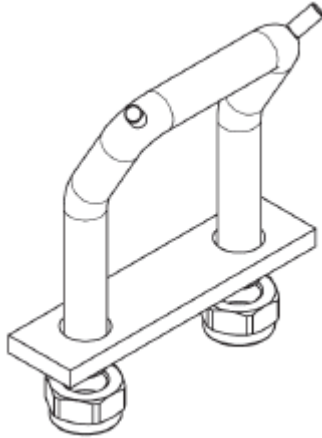

TT-no.	Description	Material / surface	Weight kg/m
0911 022.000	Anchoring shackle with thread M10	Galvanised steel	0.2

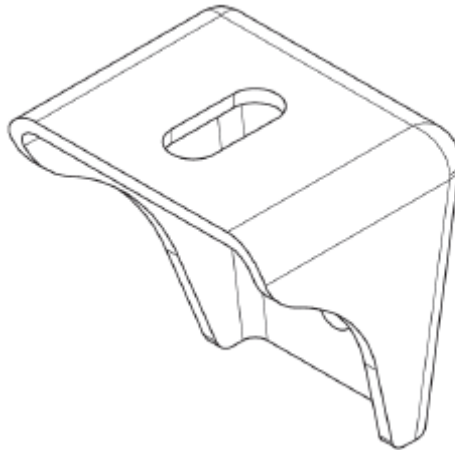

TT-no.	Description	Material / surface	Weight kg
0831 012.000	Clamp 90x83.5x4	Galvanised steel	0.45



0831 030.002



0831 030.003

TT-no.	Description	Material / surface	Weight kg
0831 030.002	Clamp spring	Galvanised steel	0.04
0831 030.003	Clamp spring bracket	Galvanised steel	0.02

3 2. Components for the canvas structure

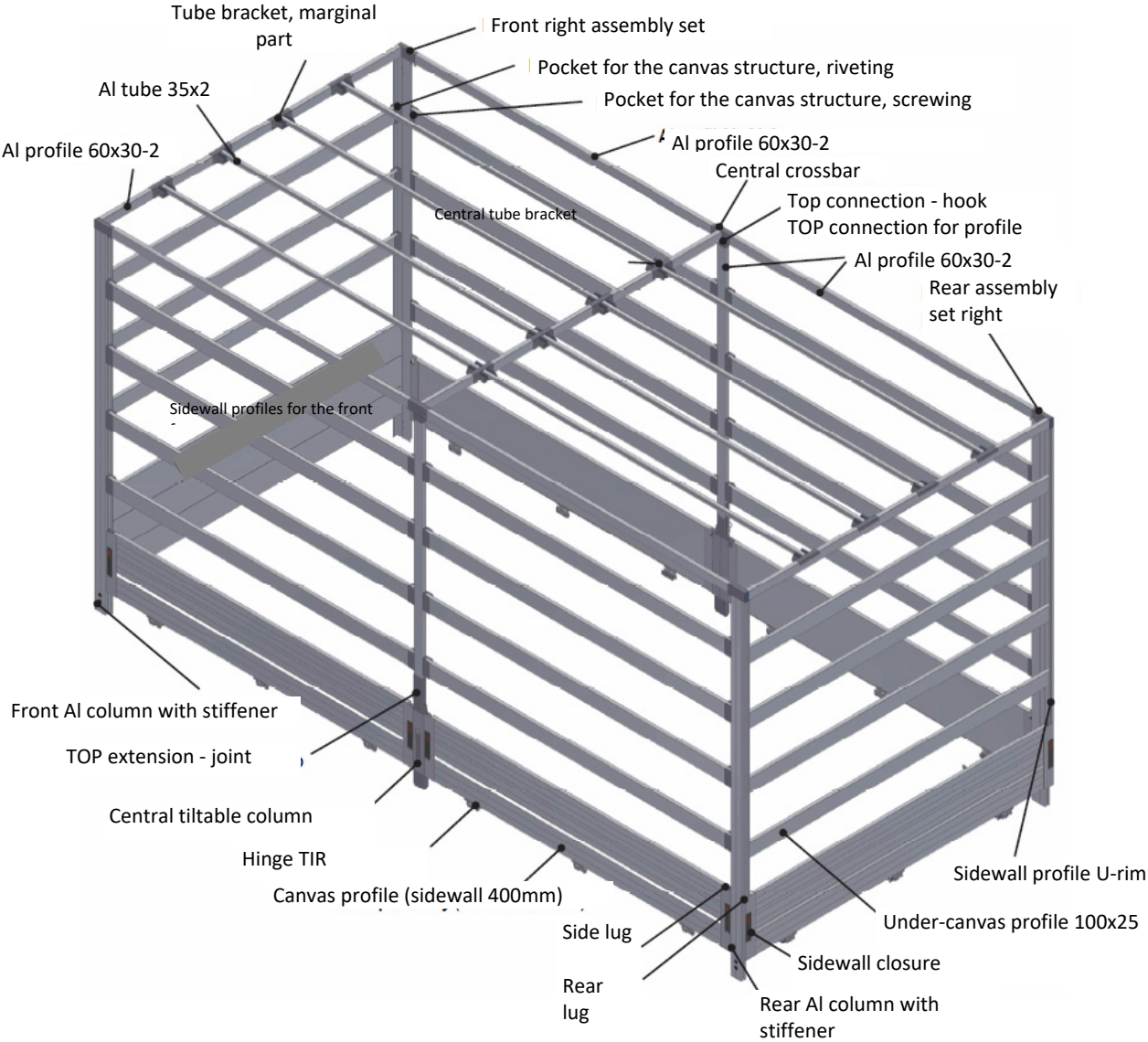

3.2.1. Al profiles of the columns.

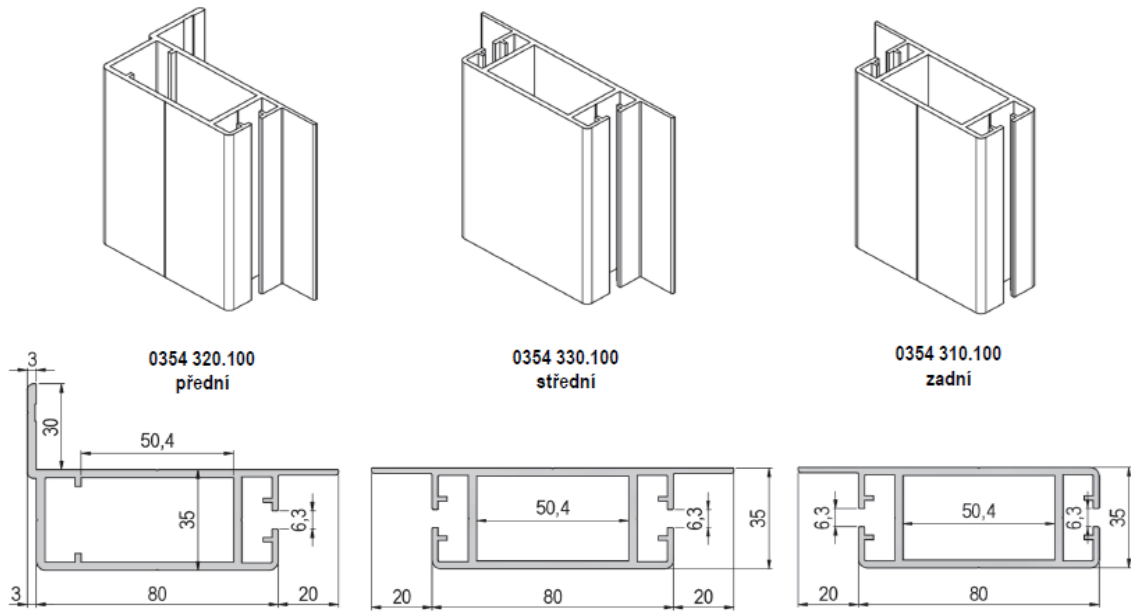

TT-no.	Description	Material / surface	Weight kg/m
0354 320.100	Aluminium column 80x35mm with rim, front	Anodized aluminium	2.17
0354 330.100	Aluminium column 80x35mm with rim, central	Anodized aluminium	2.11
0354 310.100	Aluminium column 80x35mm with rim, rear	Anodized aluminium	2

3.2.2. Corner columns stiffeners

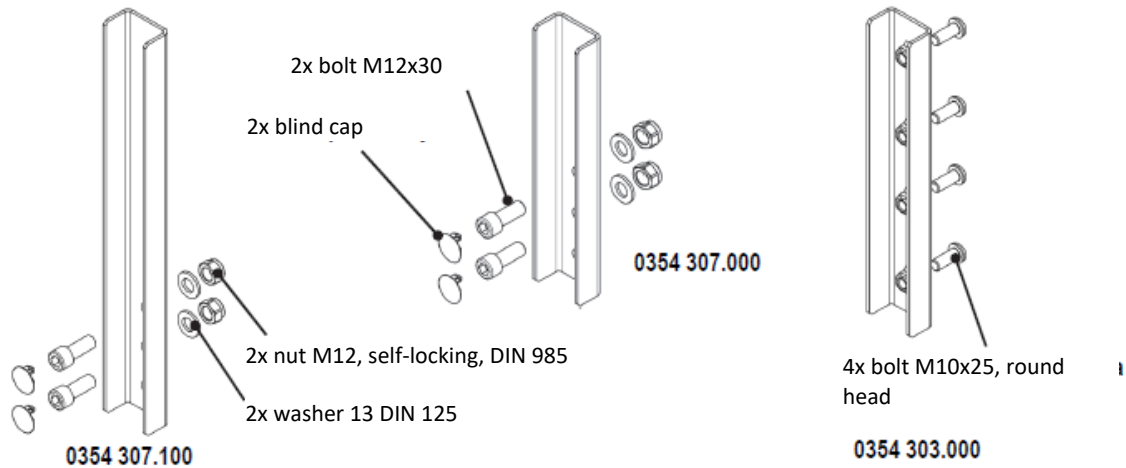

TT-no.	Description	Material / surface	Weight kg
0354 307.000	Column stiffener set, L=250mm	Galvanised steel	0.7
0354 307.100	Column stiffener set, L=400mm for telescopic column	Galvanised steel	1.1
0354 303.000	Connecting part 50x29-300 for Al column 80x35	Galvanised steel	

3.2.3. Lugs for AL columns

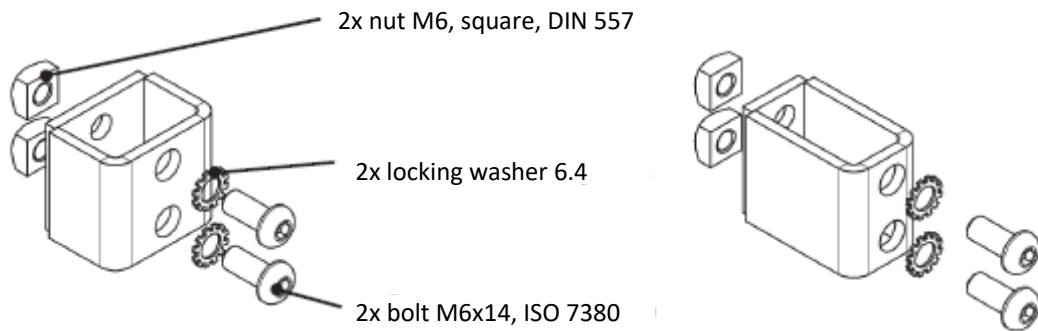

0354 309.000

0354 308.000

TT-no.	Description	Material / surface	Weight kg
0354 308.000	Side lug for AL column + connect. material	Galvanised steel	0.1
0354 309.000	Rear for AL column + connect. material	Galvanised steel	0.1

3.2.4. Central columns and their components

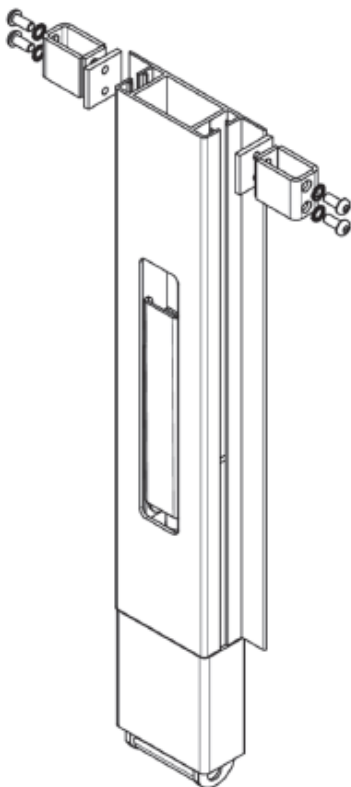

Bolt M10x25 DIN 912
 Nut M10, self-locking, DIN 985
 6x washer 10.5 DIN 125

TT-no.	Description	Material / surface	Weight kg
0311 641.200	Central column 80x35, tiltable + pocket + lugs + connecting material	Al anodized	2.8
0311 302.000	Assembly set - connect	Galvanised steel	0.2

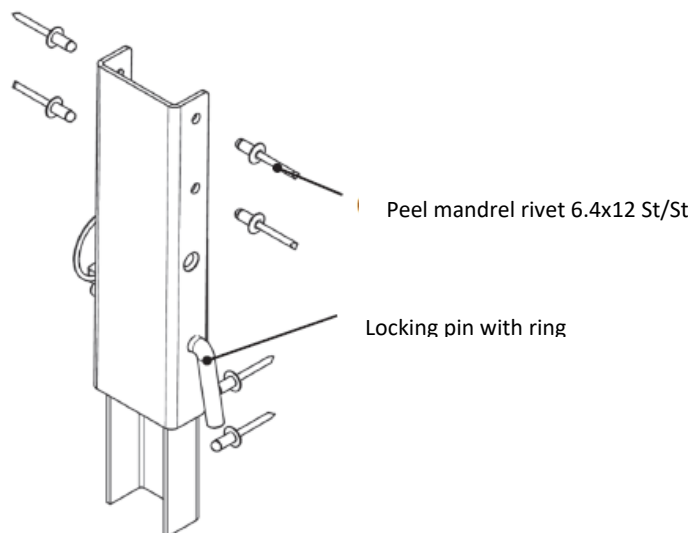

TT-no.	Description	Material / surface	Weight kg
0311 620.000	TOP joint - extension for column 80x35/60x30 + lock. pin + connect. material	Al anodized	1.6

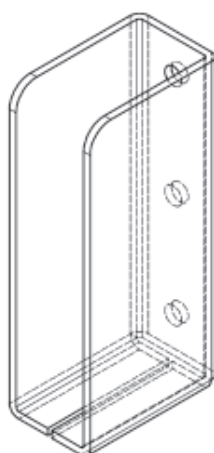

2x Peel mandrel rivet
6.4x12 St/St



2x bolt M6x14, ISO 7380
2x nut M6, square, DIN 557
2x washer 6.4 DIN 6798A

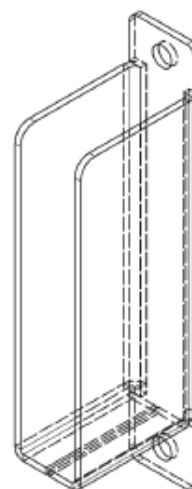

0521 372.025
0521 373.125

0521 378.025
0521 378.125

TT-no.	Description	Material / surface	Weight kg
0521 372.025	Pocket for the canvas structure 25mm, riveting, 50x100mm	Galvanised steel	0.28
0521 373.125	Pocket for the canvas structure 25mm, screw. M6 set, 50x110mm	Galvanised steel	0.29
0521 378.025	Pocket for the canvas structure 18mm, riveting, 50x100mm	Galvanised steel	0.26
0521 378.125	Pocket for the canvas structure 18mm, screw. M6 set, 50x110mm	Galvanised steel	0.27

3.2.5. Sidewall profiles, under-canvas profiles

Lower profile 100mm for sealing			
TT-no.	Surface	Material	Weight
0411 002.000	natural	AlMgSi 0.5	1.6 kg/m
0412 002.000	anodized		

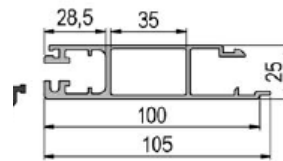

Lower profile 200mm for sealing			
TT-no.	Surface	Material	Weight
0411 004.000	natural	AlMgSi 0.5	2.67 kg/m
0412 004.000	anodized		

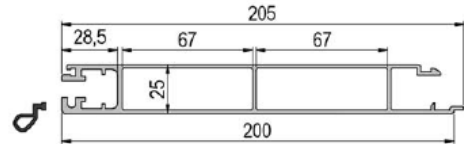

Central profile 200mm			
TT-no.	Surface	Material	Weight
0411 024.000	natural	AlMgSi 0.5	1.90 kg/m
0412 024.000	anodized		

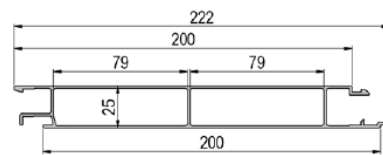

Upper profile 200mm			
TT-no.	Surface	Material	Weight
0411 051.000	natural	AlMgSi 0.5	2.52 kg/m
0412 051.000	anodized		

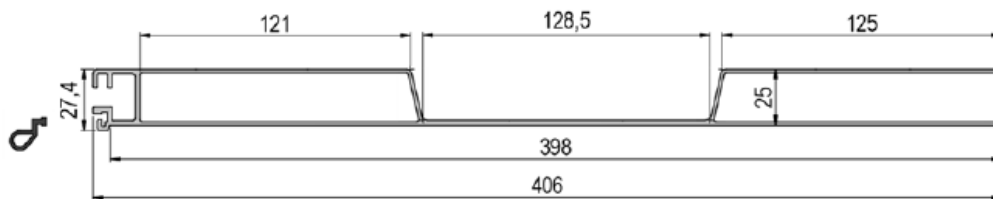
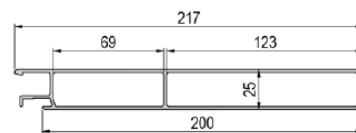

Canvas profile 406mm			
TT-no.	Surface	Material	Weight
0411 104.000	natural	AlMgSi 0.5	4.25 kg/m
0412 104.000	anodized		



Sidewall sealing		
TT-no.	Material	Weight
0413 002.000	PVC	0.10 kg/m

Profile 150mm			
TT-no.	Surface	Material	Weight
0411 091.000	natural	AlMgSi 0.5	1.7 kg/m
0412 091.000	anodized		

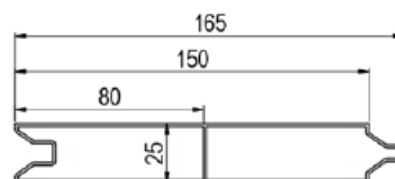

Profile 100mm			
TT-no.	Surface	Material	Weight
0411 092.000	natural	AlMgSi 0.5	1.1 kg/m

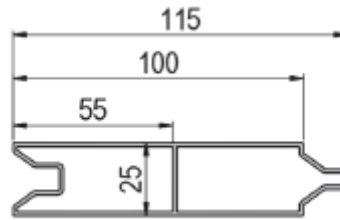

Under-canvas profile 100x25			
TT-no.	Surface	Material	Weight
0411 093.000	natural	AlMgSi 0.5	1.17 kg/m

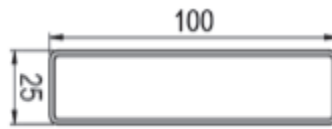

Under-canvas profile 100x25 with partition			
TT-no.	Surface	Material	Weight
0411 094.000	natural	AlMgSi 0.5	0.9 kg/m

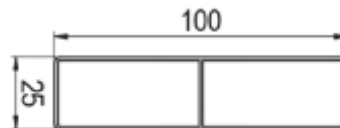

Blind cap for profile 100x25			
TT-no.	Surface	Material	Weight
0413 093.000	black	PU	0.03 kg

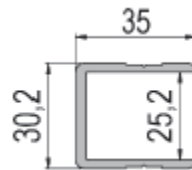
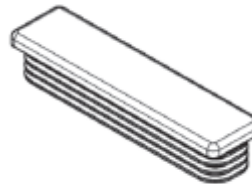

TT-no.	Description	Material / surface	Weight kg
0412 072.000	Sidewall rim profile (U 35x30.2x2.8)	AlMgSi 0,5, anodized	0.6 kg/m
0354 304.000	Set for installation of the U-profile on the lathes above the rear face	Galvanised steel	

3.2.6. Hinge TIR

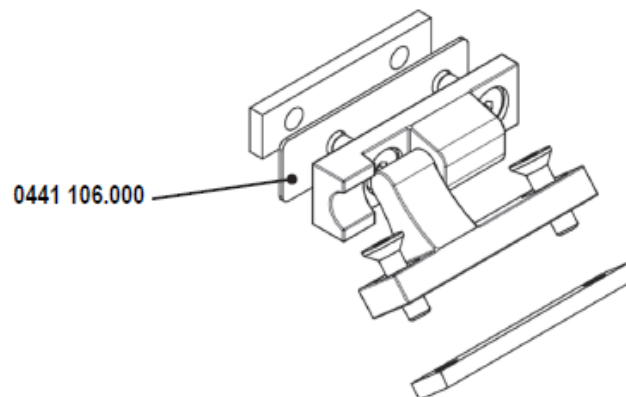

TT-no.	Description	Material / surface	Weight kg
0441 111.004	Hinge TIR. complete, for profile 406mm	Galvanised steel	0.6
0441 106.000	Distance pad under hinge TIR 88/25/50, 1.5mm thick	Galvanised steel	0

3.2.7. Sidewall closures

TT-no.	Description	Material / surface	Weight kg
0422 125.411	Sidewall closure 405 L without rim, plastic lock	Aluminium, anodized	1.25
0422 125.412	Sidewall closure 405 R without rim, plastic lock	Aluminium, anodized	1.25
0413 078.000	Rubber plug 40x25mm to rim closures	Rubber, black	0.02

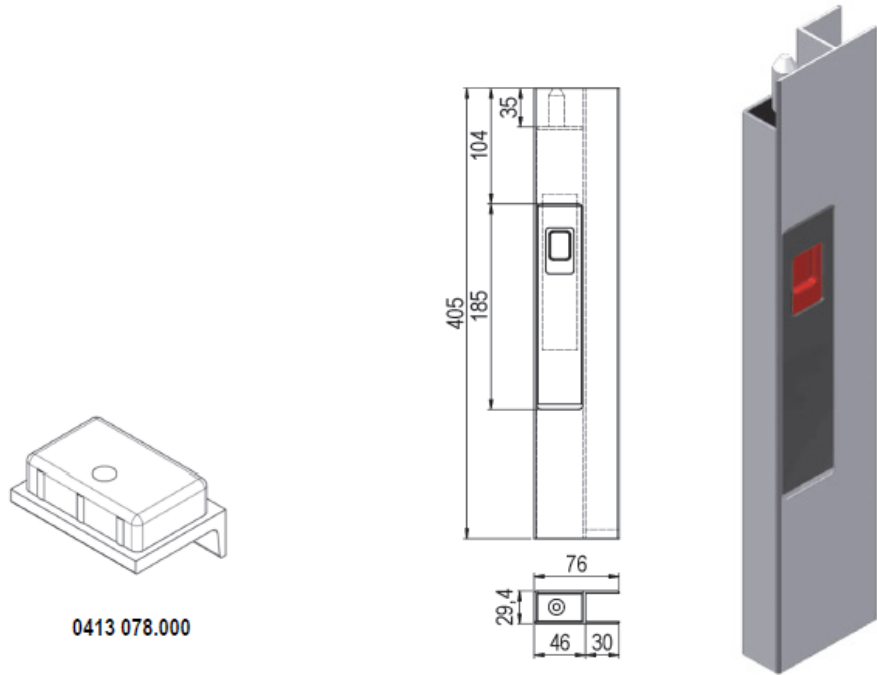

TT-no.	Description	Material / surface	Weight kg
0422 124.411	Sidewall closure 404 L without rim, without plastic lock	Aluminium, anodized	1.25
0422 124.412	Sidewall closure 404 R without rim, without plastic lock	Aluminium, anodized	1.25
0413 078.000	Rubber plug 40x25mm to rim closures	Rubber, black	0.02

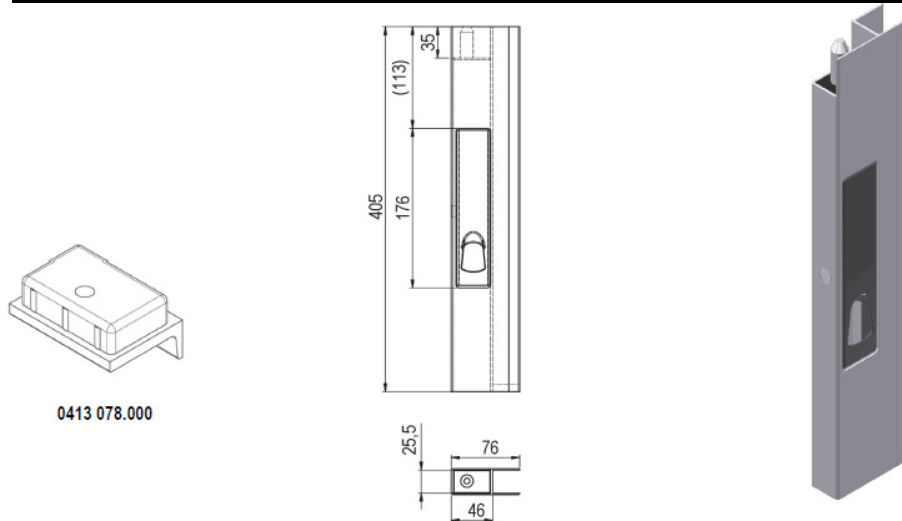

3.2.8. Tube roof assembly sets, non-lifting

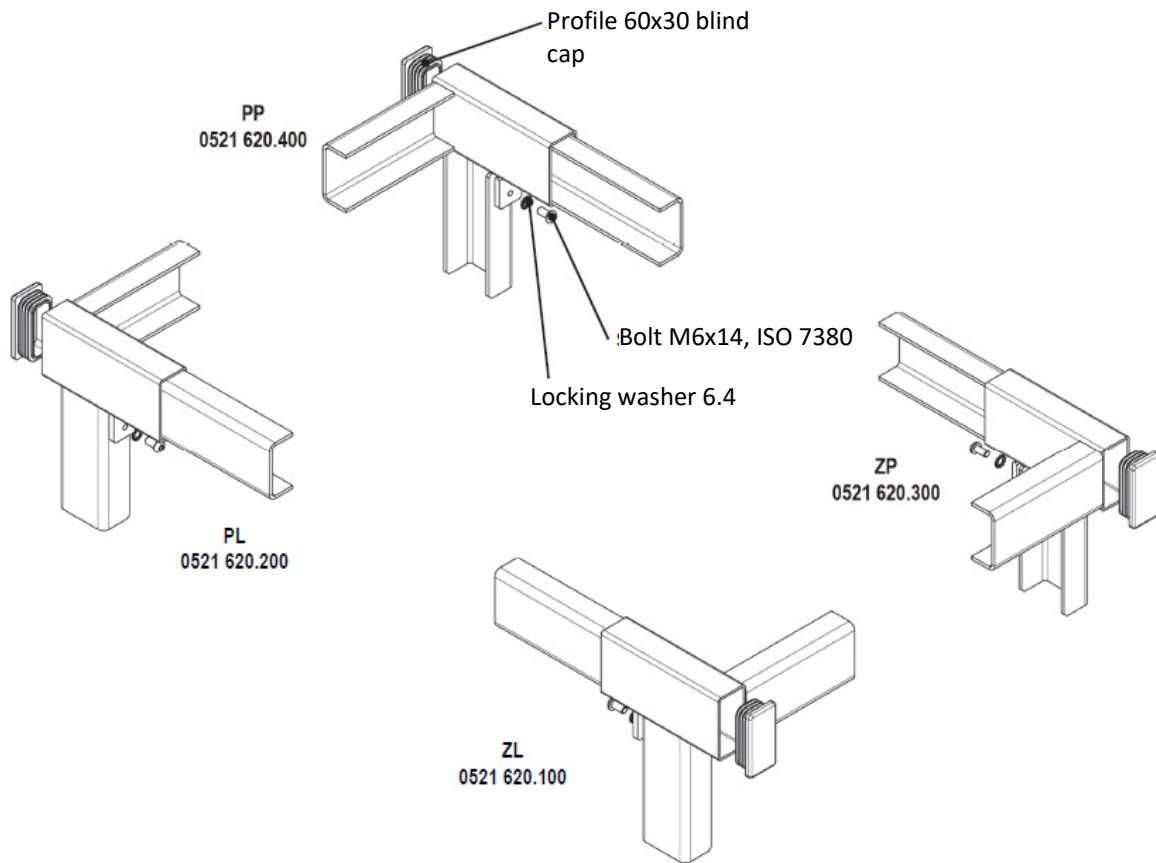

TT-no.	Description	Material / surface	Weight kg
0521 620.100	RL assembly set, non-lifting, for column 80x35mm	Galvanised steel	1.3
0521 620.200	FL assembly set, non-lifting, for column 80x35mm	Galvanised steel	1.3
0521 620.300	RR assembly set, non-lifting, for column 80x35mm	Galvanised steel	1.3
0521 620.400	FR assembly set, non-lifting, for column 80x35mm	Galvanised steel	1.3

3.2.9. Tube roof

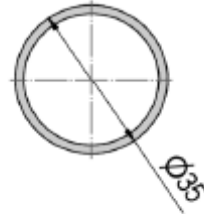
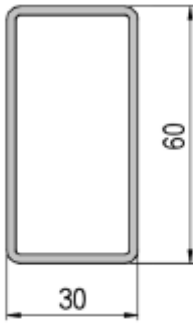

TT-no.	Description	Material / surface	Weight kg/m
0410 264.002	Al profile 60x30x2mm, R3	Aluminium, natural	0.34
0521 307.000	Al tube 35x2mm	Aluminium, natural	0.56

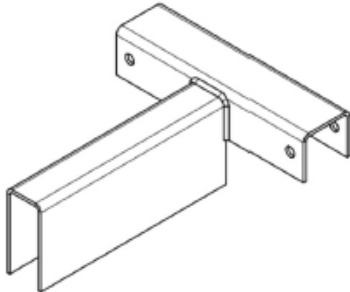

0521 612.000

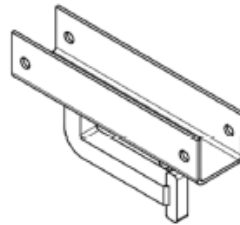

0521 613.000

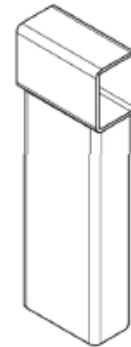

0521 614.000

TT-no.	Description	Material / surface	Weight kg
0521 612.000	Central crossbar bracket	Galvanised steel	0.5
0521 613.000	TOP connection - hook	Galvanised steel	0.3
0521 614.000	TOP connection for profile 60x30mm	Galvanised steel	0.3

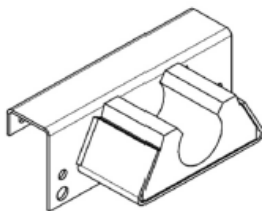

0521 616.000
0521 302.000

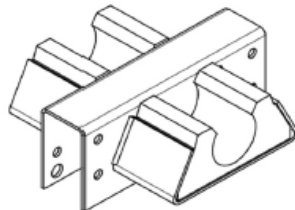

0521 617.000
0521 302.000

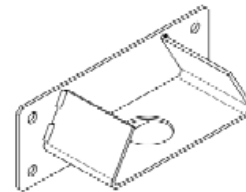

0521 518.100

TT-no.	Description	Material / surface	Weight kg
0521 616.000	Tube bracket, marginal part	Galvanised steel	0.5
0521 617.000	Central tube bracket	Galvanised steel	0.8
0521 302.000	Rubber part for tubes \varnothing 35mm	Rubber	0.09
0521 518.100	35mm tube bracket, marginal, riveting	Galvanised steel	0.5

3.2.10. Lifting roof parts

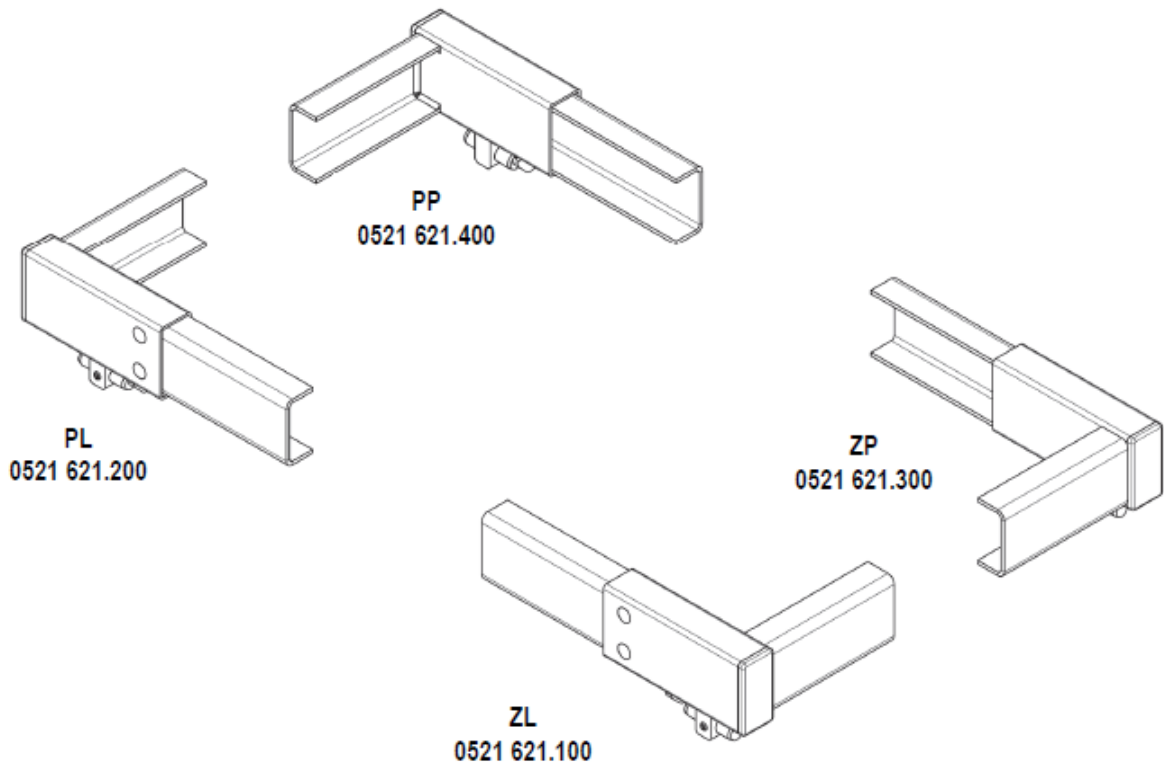

TT-no.	Description	Material / surface	Weight kg
0521 621.100	RL assembly set, lifting, for column 80x35mm	galvanised steel	1.1
0521 621.200	FL assembly set, lifting, for column 80x35mm	galvanised steel	1.1
0521 621.300	RR assembly set, lifting, for column 80x35mm	galvanised steel	1.1
0521 621.400	FR assembly set, lifting, for column 80x35mm	galvanised steel	1.1



TT-no.	Description	Material / surface	Weight kg
0521 604.000	TOP connection, telescopic, for column 80x35	galvanised steel	1

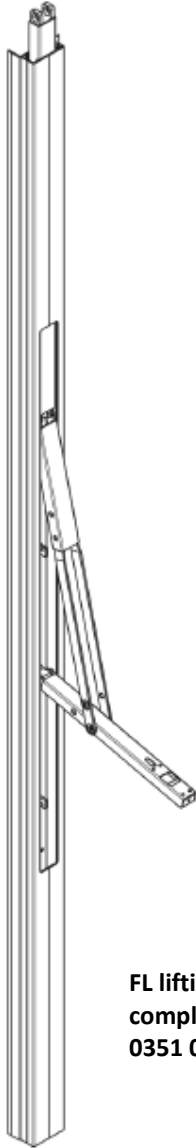

**FL lifting mechanism,
complete
0351 072.200**

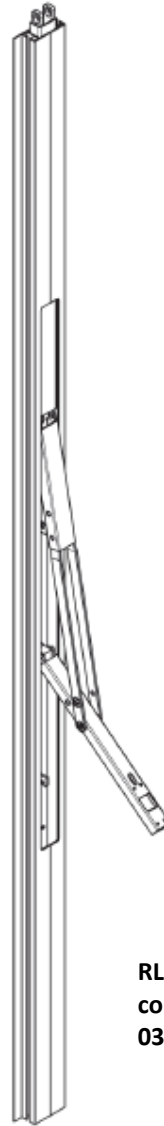

**RL lifting mechanism,
complete
0351 072.200**

TT-no.	Description	Material / surface	Weight kg
0351 072.100	RL lifting mechanism, Al column TT 80x35	aluminium, galvanised steel	12
0351 072.200	FL lifting mechanism, Al column TT 80x35	aluminium, galvanised steel	12.5
0351 072.300	RR lifting mechanism, Al column TT 80x35	aluminium, galvanised steel	12
0351 072.400	FR lifting mechanism, Al column TT 80x35	aluminium, galvanised steel	12.5

3.2.12 Tube angled roof, assembly sets, non-lifting

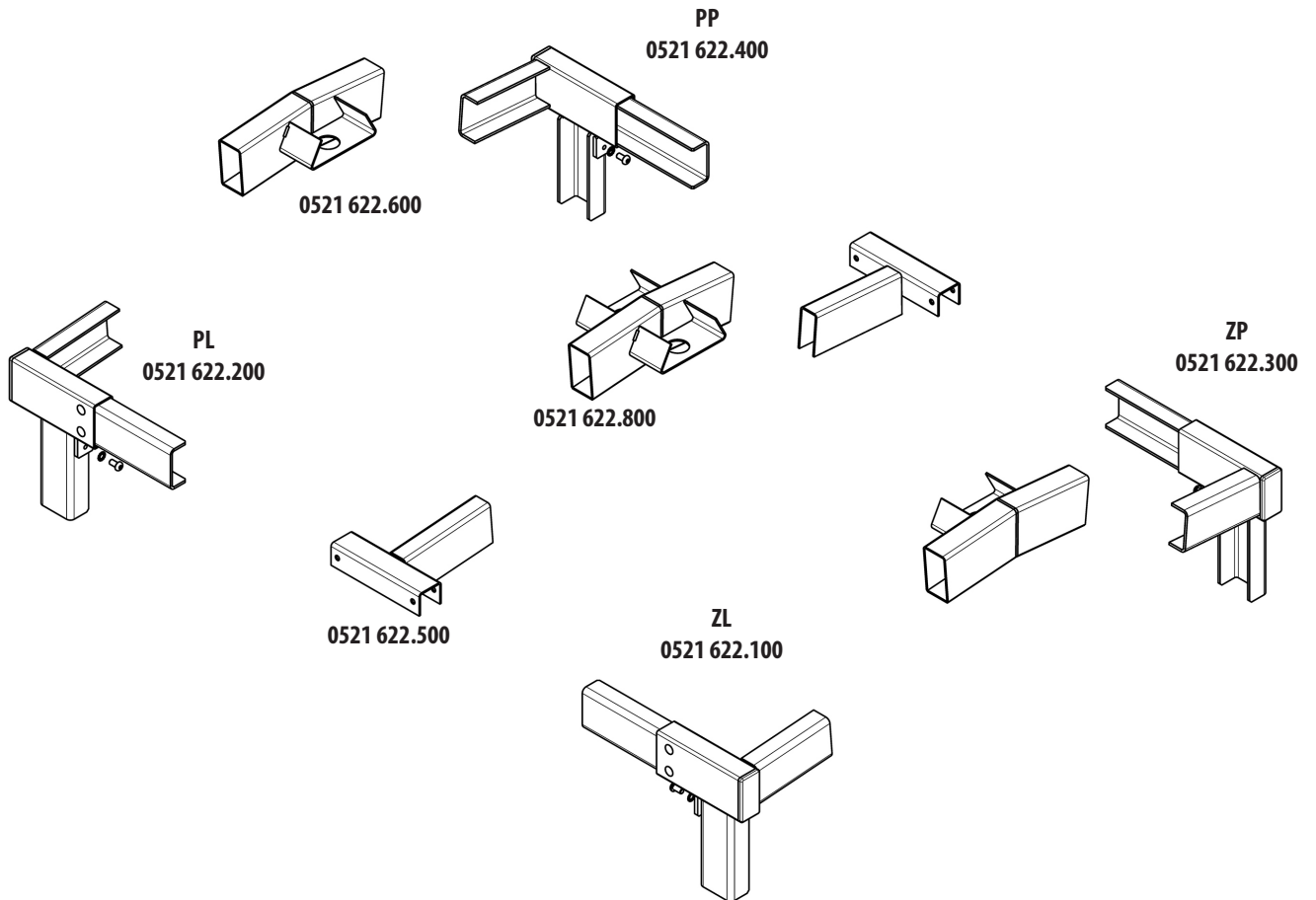

TT-number	Name	Material Material	Weight kg /
0521 622.100	RL assembly set tube angle roof a	galvanised steel	1,3
0521 622.200	FL assembly set tube angle roof a	galvanised steel	1,3
0521 622.300	RR assembly set tube angle roof a	galvanised steel	1,3
0521 622.400	FR assembly set tube angle roof a	galvanised steel	1,3

3.2.13 Tube angled roof parts

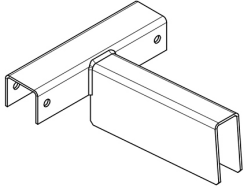
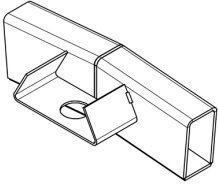
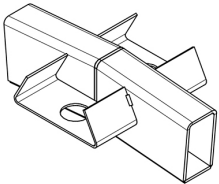
TT-number	Name	Drawing
0521 622.500	Holder central part (angled roof)	
0521 622.600	Assembly set Front / rear (angled roof)	
0521 622.800	Assembly set central (angled roof)	

3.2.12. Gate parts

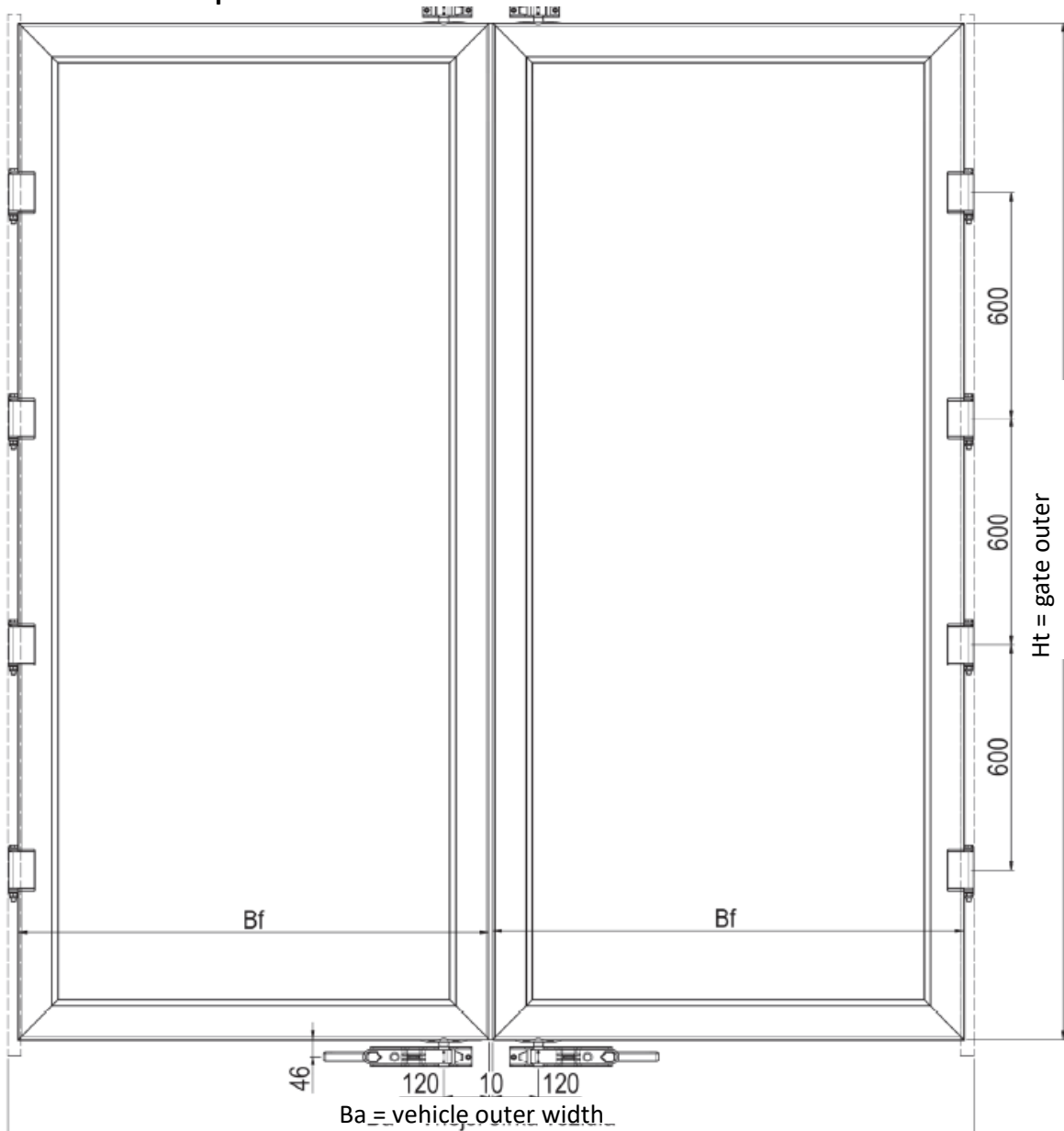

TT-no.	Description	Material / surface	Weight kg
0512 001.22X	Gate TT COMPLETE 2K/2U, anodized frame, panel filling	Anodized aluminium	80

**Optional use of aluminium riveted hanger.*

TT-no.	Description	Material / surface	Weight kg
0512 019.270	Riveted hanger L=2,700	Aluminium, natural	4
0512 020.270	Riveted hanger L=2,700	Anodized aluminium	4
0512 019.315	Riveted hanger L=3,150	Aluminium, natural	4.6
0512 020.315	Riveted hanger L=3,150	Anodized aluminium	4.6

3.3. Rear portal with flap

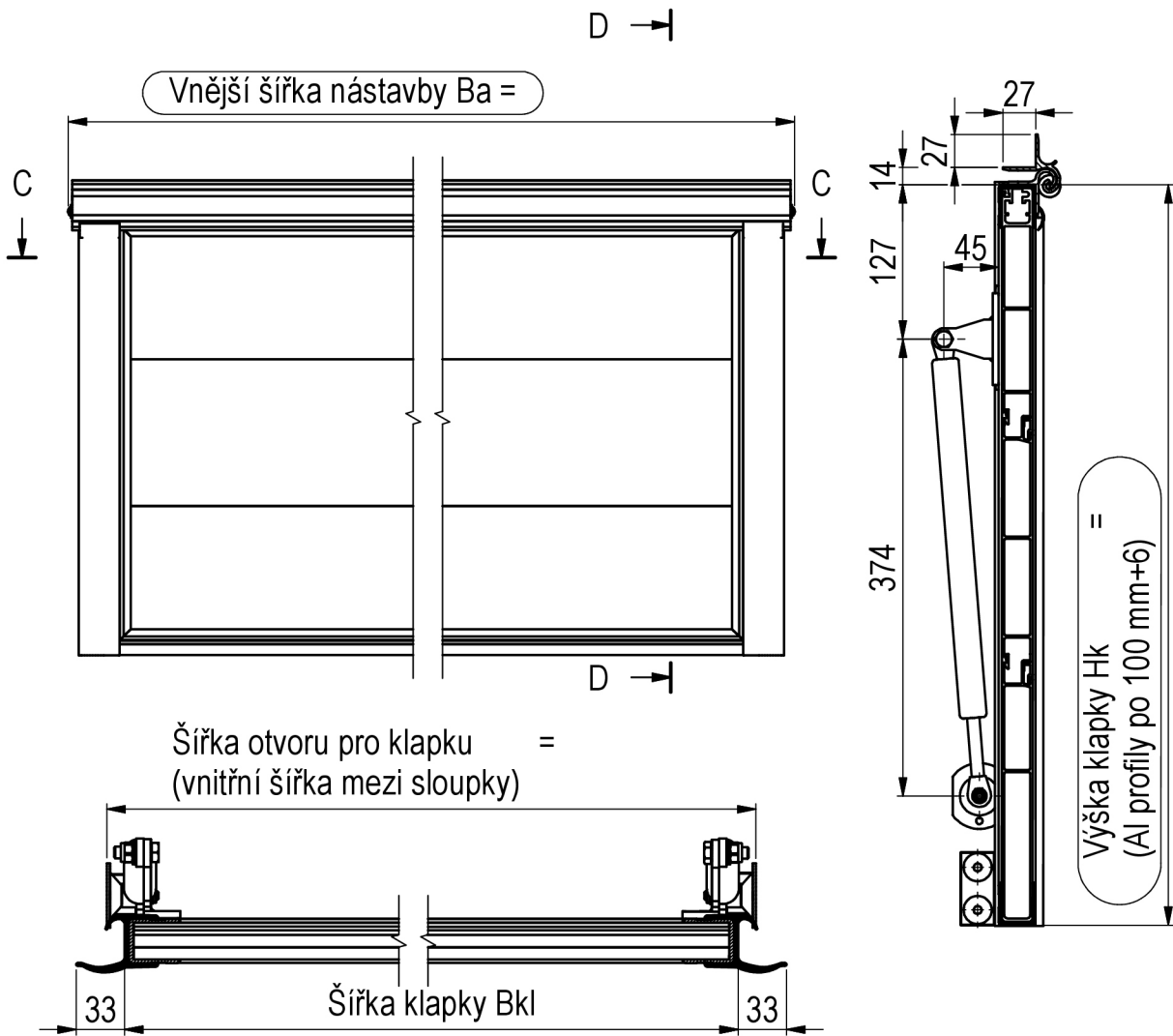

3.4. Rear portal with flap

Assembly with profile **80 x 30mm / 60 x 30mm**
recommended for **PENTA CITY, FIXO, FIXO-S, LIGHT PLATFORME**

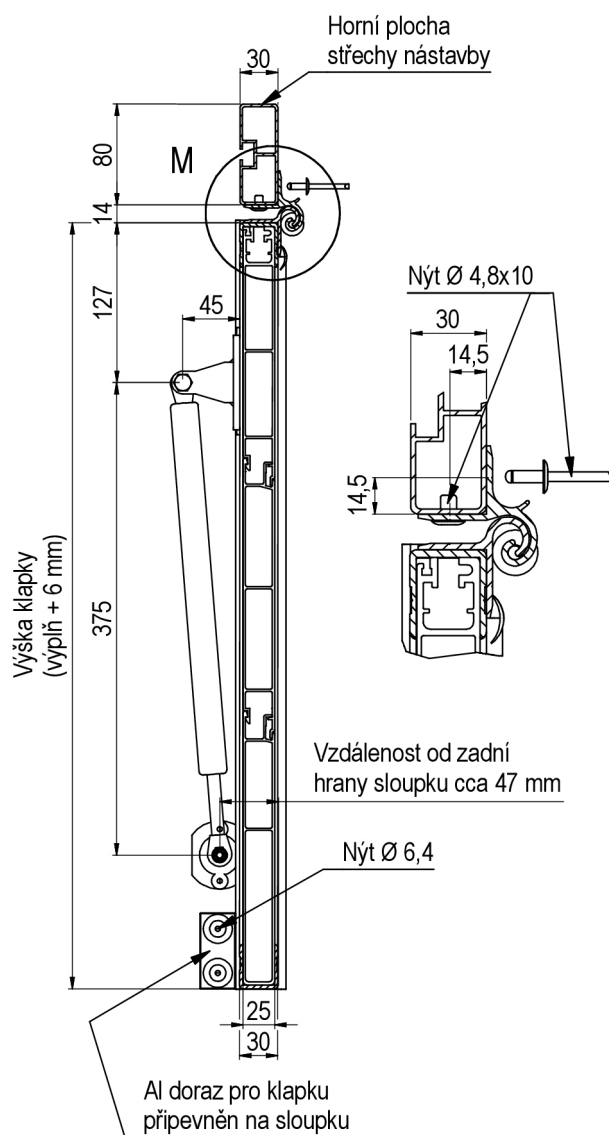

3.5. Rear portal with flap

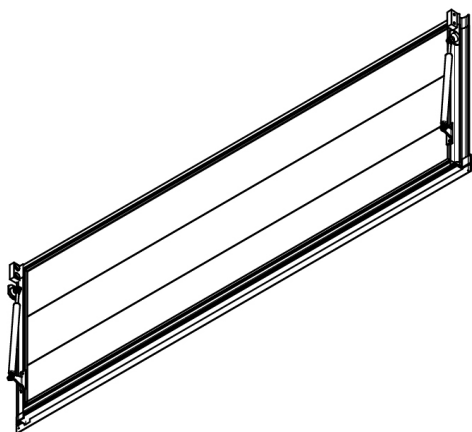

Height flap	Outer width	Width flap (max.šířka)	TT number/ materiál klapky			Streingth gas springs	Weight
H mm	Ba max mm	Bkl max mm	TT-number	TT-number elox	TT-number rám elox výplň panel	F (N)	kg / pcs
500	2100	2010	0561 050.021	0561 050.121	0561 050.221	2 x 260	
	2200	2110	0561 050.022	0561 050.122	0561 050.222	2 x 260	
	2300	2210	0561 050.023	0561 050.123	0561 050.223	2 x 260	
	2400	2310	0561 050.024	0561 050.124	0561 050.224	2 x 260	
	2550	2460	0561 050.025	0561 050.125	0561 050.225	2 x 260	
600	2100	2010	0561 060.021	0561 060.121	0561 060.221	2 x 260	
	2200	2110	0561 060.022	0561 060.122	0561 060.222	2 x 260	
	2300	2210	0561 060.023	0561 060.123	0561 060.223	2 x 260	
	2400	2310	0561 060.024	0561 060.124	0561 060.224	2 x 260	
	2550	2460	0561 060.025	0561 060.125	0561 060.225	2 x 260	

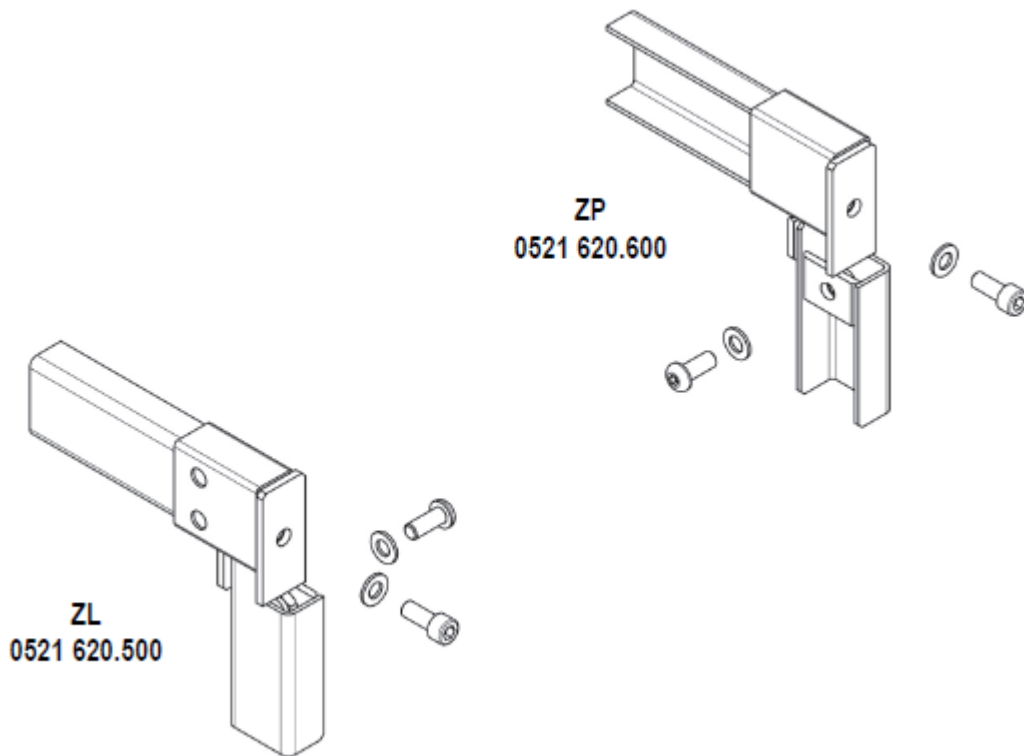

TT-no.	Description	Material / surface	Weight kg
0521 620.500	RL assembly set, non-lifting, for gate	Galvanised steel	1.1
0521 620.600	RR assembly set, non-lifting, for gate	Galvanised steel	1.1

3.2.13. Accessories

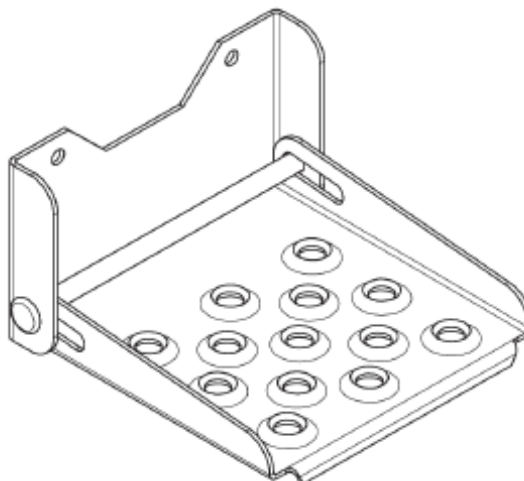

TT-no.	Description	Material / surface	Weight kg
0841 008.000	Tiltable step	Galvanised steel	1.3

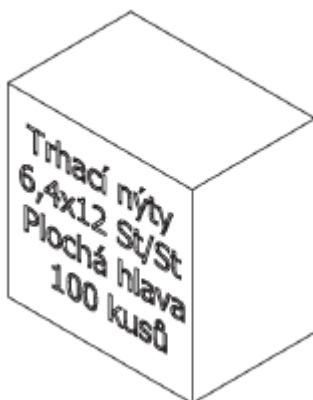

Peel mandrel rivets
6.4x12 St/St
Flat head
100 pcs

TT-no.	Description	Material / surface	Weight kg
2111 464.122	Peel mandrel rivet 6,4x12 Flat head 100 pcs For roof assembly	St/St	0.7

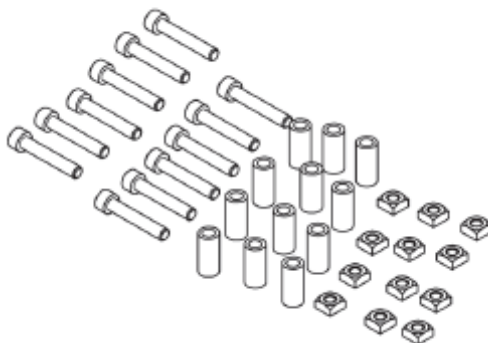

10x bolt M8x35, cyl. head, galvanised, DIN 912, ISO 4762
14x nut M6, square, DIN 557
10x plastic distance piece 6.2x10x21.5
4x bolt M6x16, cyl. head, galvanised, DIN 912, ISO 4762
4x spring washer 6 DIN 7980

TT-no.	Description	Material / surface	Weight kg
0354 304.000	Set for installation of the U-profile on lathes above the rear face	St/St	0.7



0521 610.960

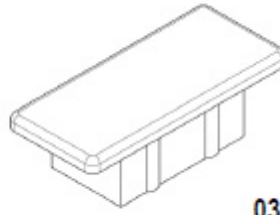

0354 341.000

TT-no.	Description	Material / surface	Weight kg
0521 610.960	Profile 60x30 blind cap	Plastic/black	0.02
0354 341.000	Column 80x35 blind cap	Rubber, black	0.03

3 3. Stand for sidewall for column 60x30x2, complete

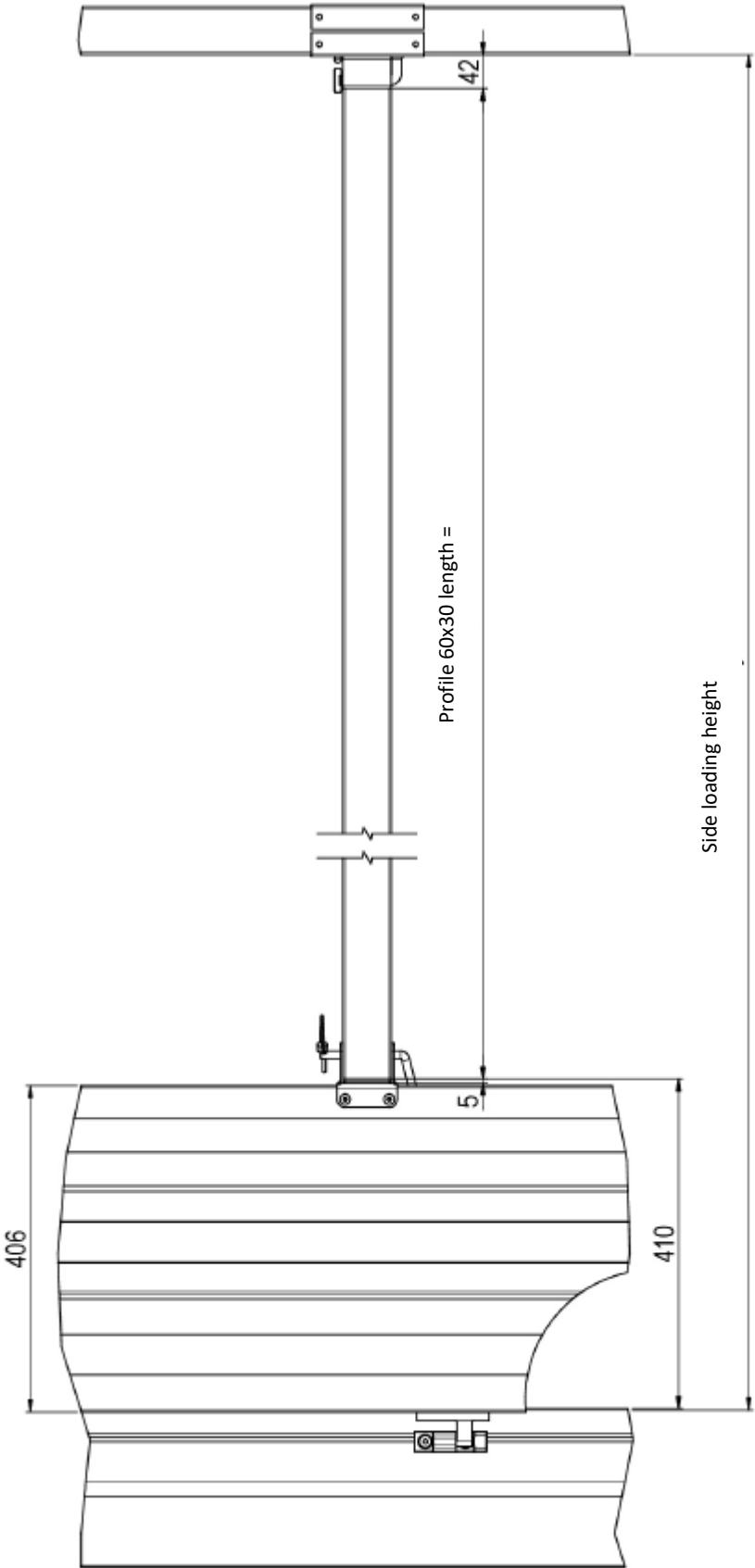

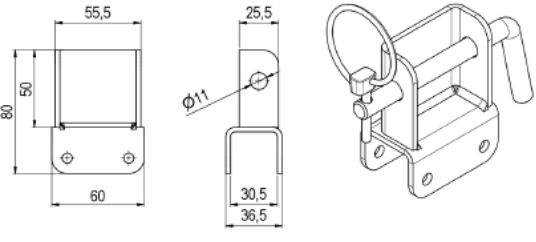
TT-no.	Description	Sketch
0311 622.100	Stand for sidewall for column 60x30x2, complete Material: galvanised steel	
0311 622.101	Stand for sidewall	
0871 316.000	Superstructure locking pin	
0871 401.000	Locking pin with ring	



4. Assembly of a platform car canvas structure

4 1. Installation of the platform

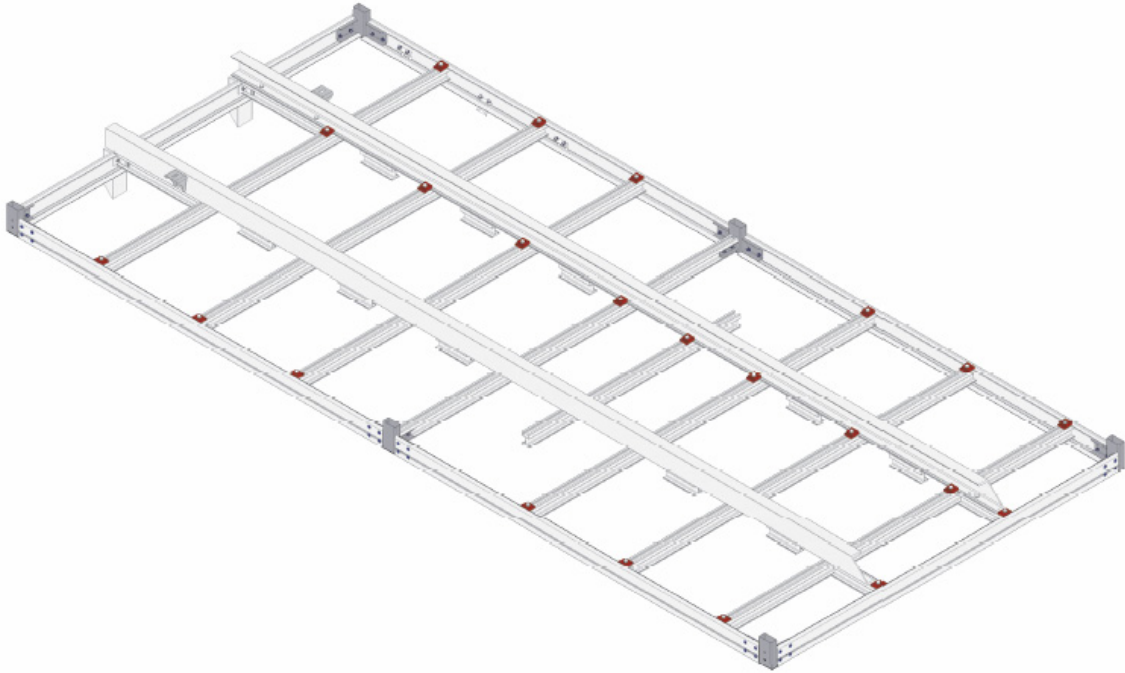

The platform is integral part of the platform car superstructure and serves as a supporting element of the whole superstructure. The platform consists of aluminium profiles and steel corners that are then used for fixing of Al columns.

The platform assembly begins with measurement of spacing of the longitudinal beams cut to the desired lengths with tolerance ± 1 mm. The crosspieces shall be fixed to the longitudinal profile using the Palcom clamps. When using the Palcom clamps, apply adhesive for screwed connections.

- **Installation of the Palcom clamps - connection of rear stiffeners with longitudinal profiles**

The Palcom clamps are used for connection of longitudinal, cross and frame aluminium profiles and front and rear stiffeners. Maximum tightening torque for fixing of the Palcom clamps is 49Nm.

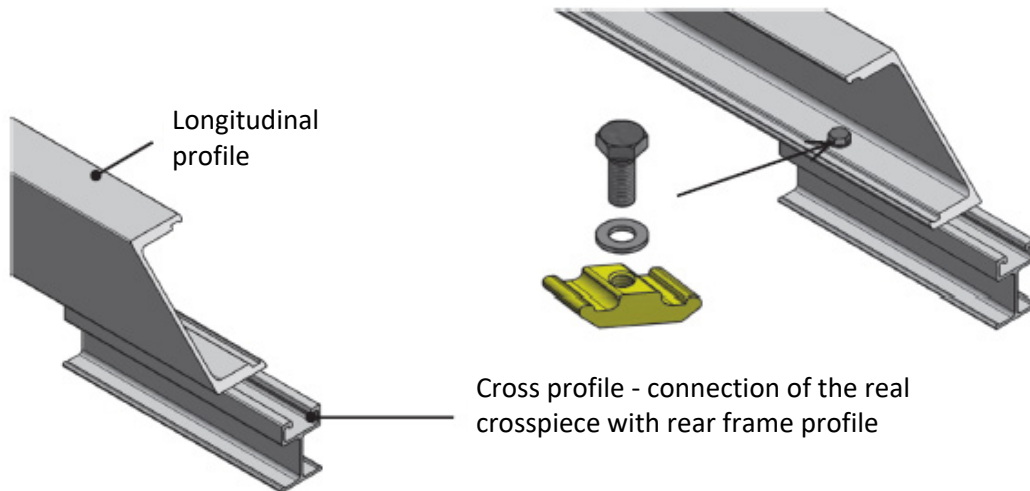

- **Installation of Palcom clamps - connection of cross profiles with longitudinal profiles and frame profile**

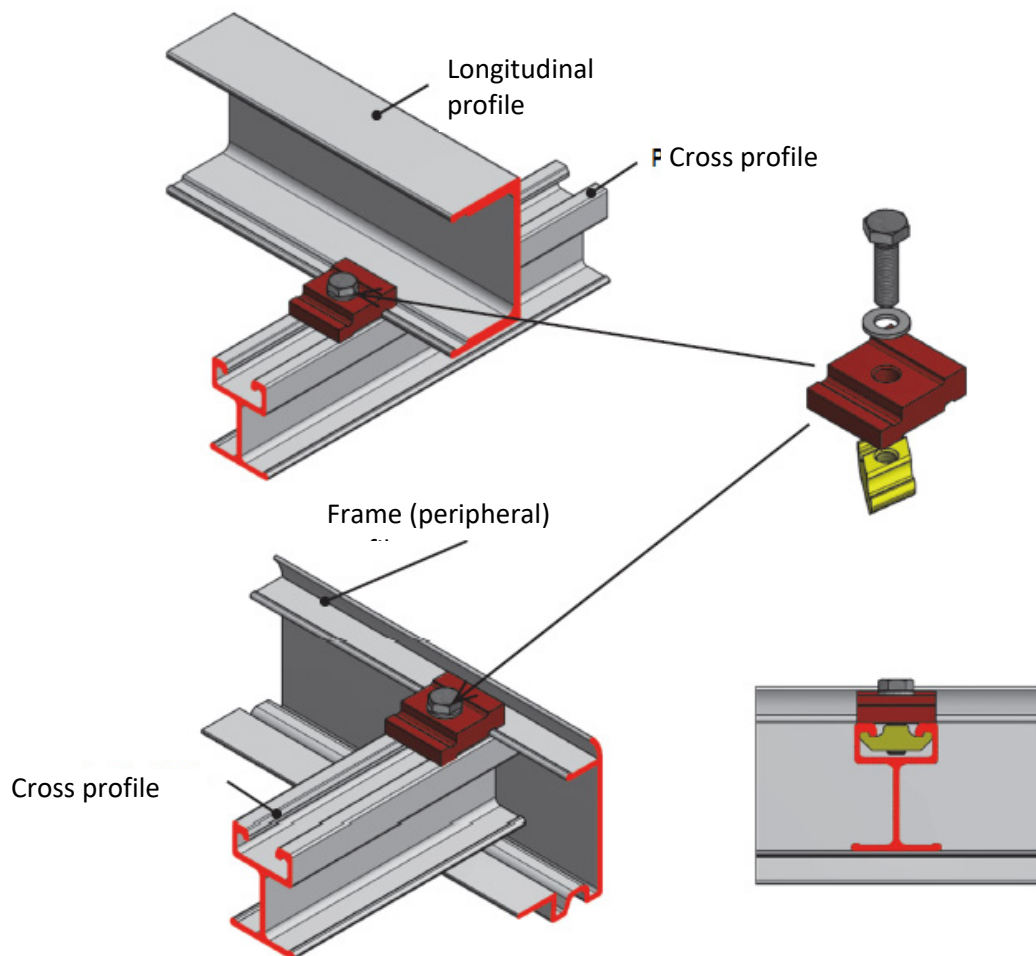

- **Installation of the Palcom clamps - connection of front stiffeners with longitudinal profiles Var. 1**

The Palcom clamps are used for connection of longitudinal, cross and frame aluminium profiles and front and rear stiffeners.

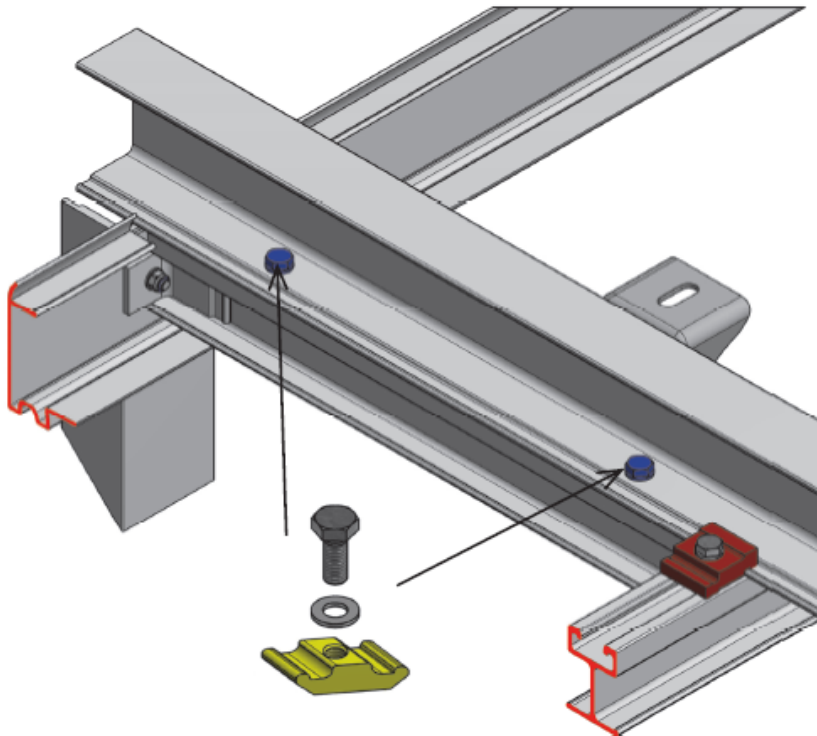

- **Cutting of a front frame profile for seating of the longitudinal profiles ahead**

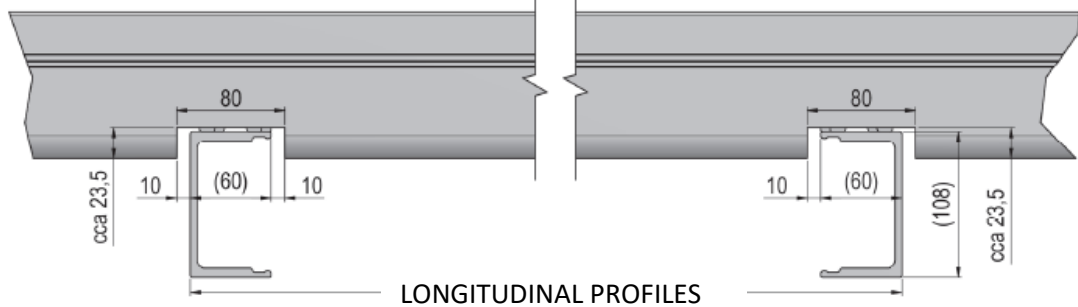

- **Installation of the Palcom clamps - connection of front stiffeners with longitudinal profiles Var. 2**

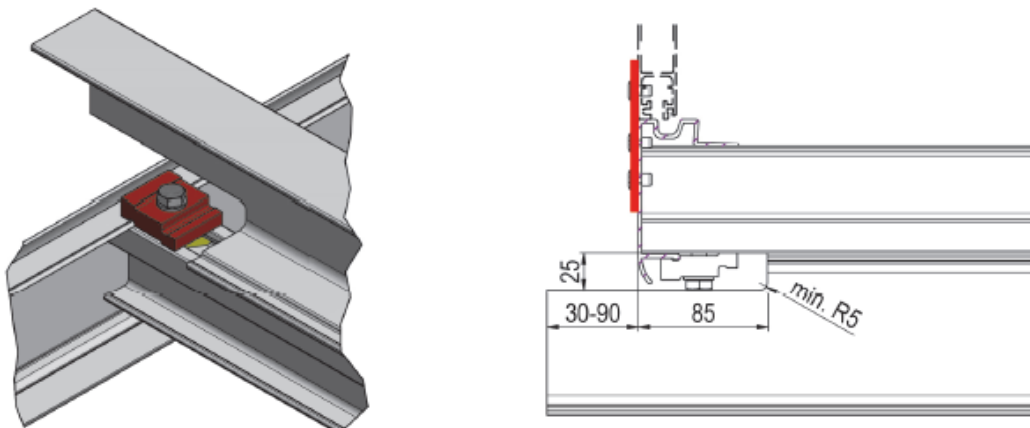

- Installation of a rear frame profile to a longitudinal profile

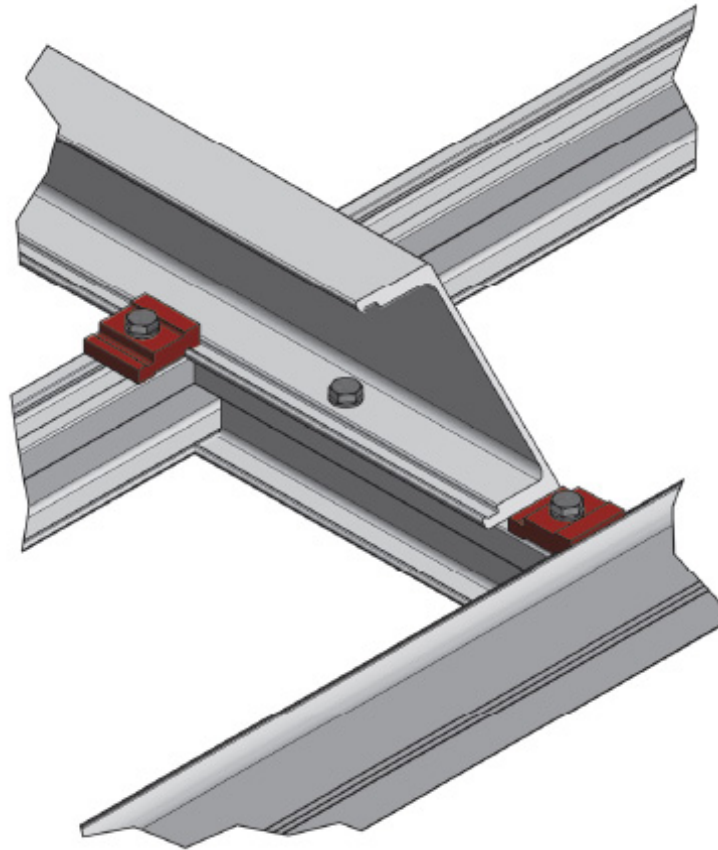

- installation of a stop for the front face

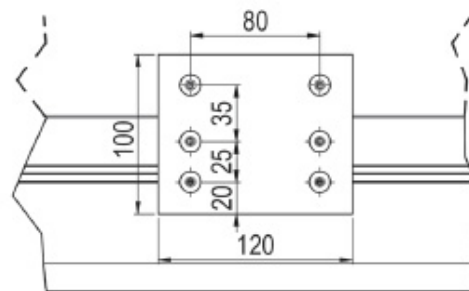
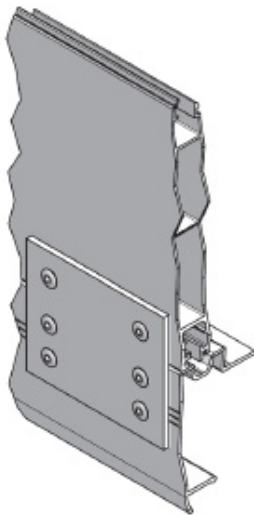

- Installation of the platform corners, frame peripheral profiles and central part

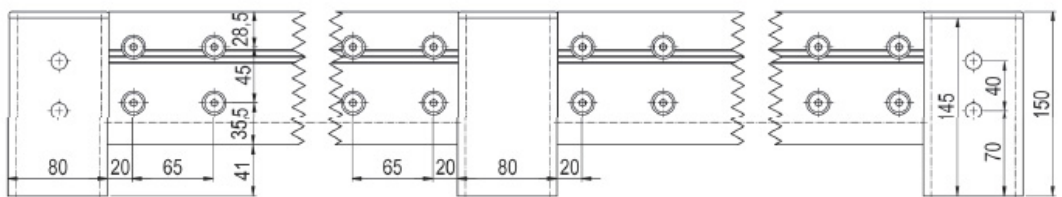
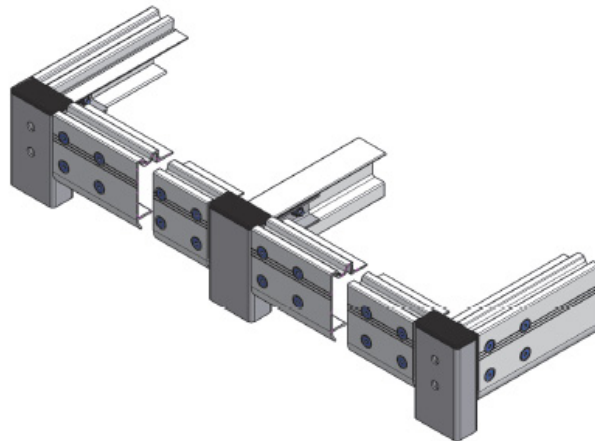
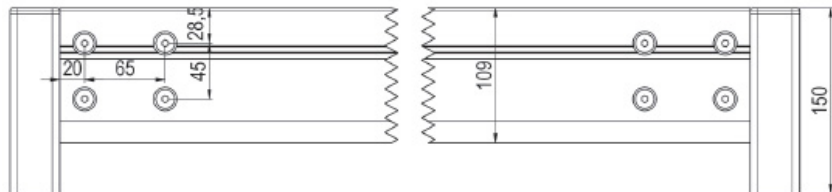
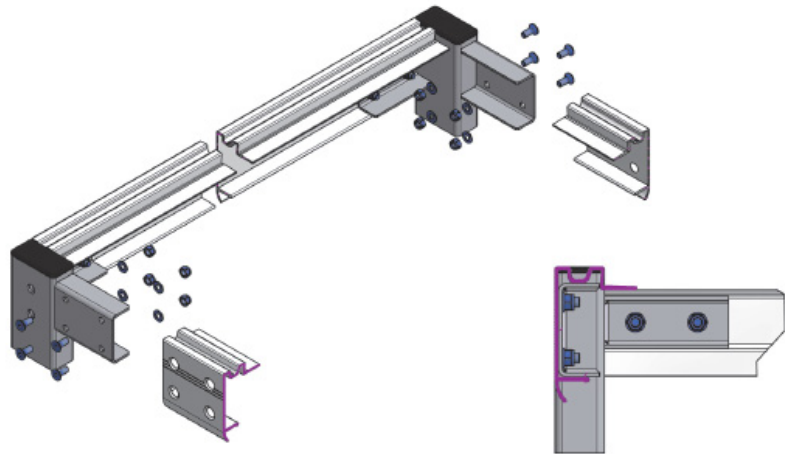

- Installation of a central stiffener for the central column

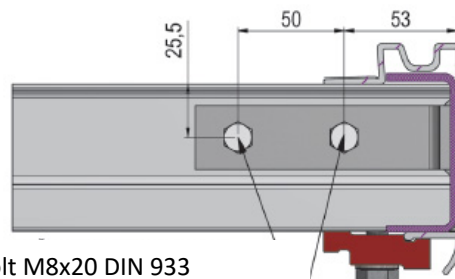
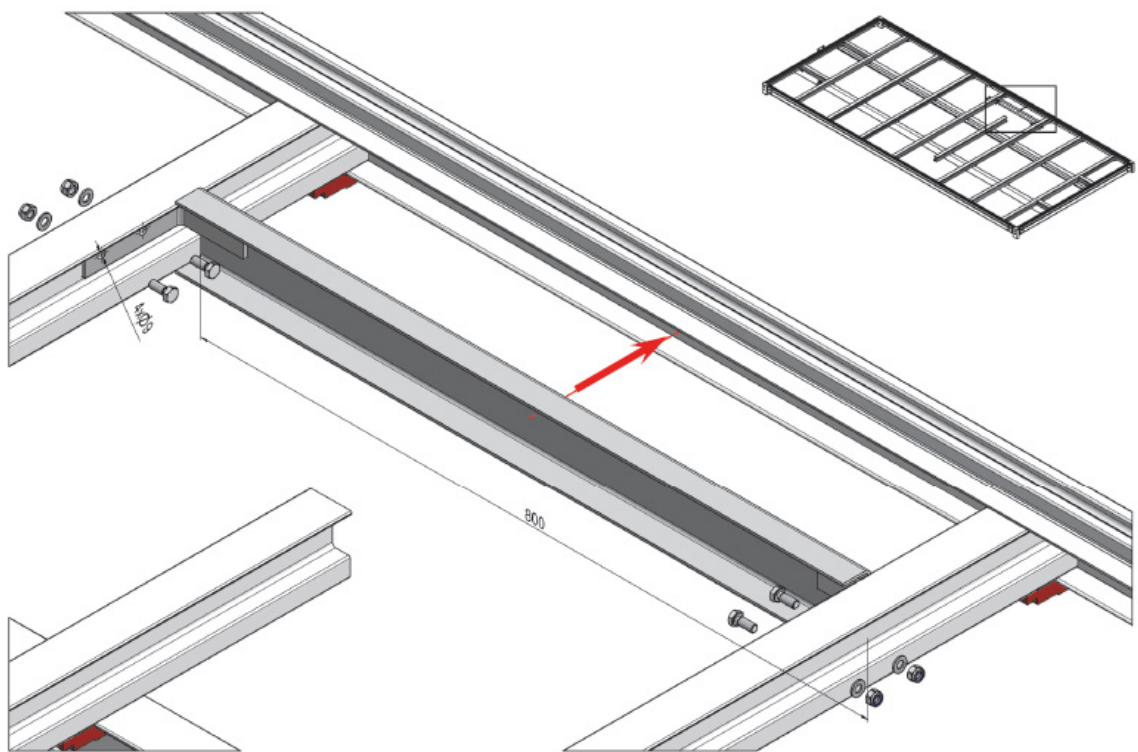

- 4x bolt M8x20 DIN 933
- 4x nut, self-locking, DIN 985
- 4x washer 8.4 DIN 125

- Installation of anchoring shackles and clamps to the chassis

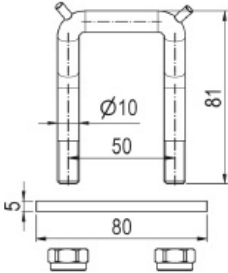
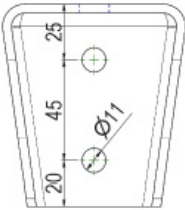
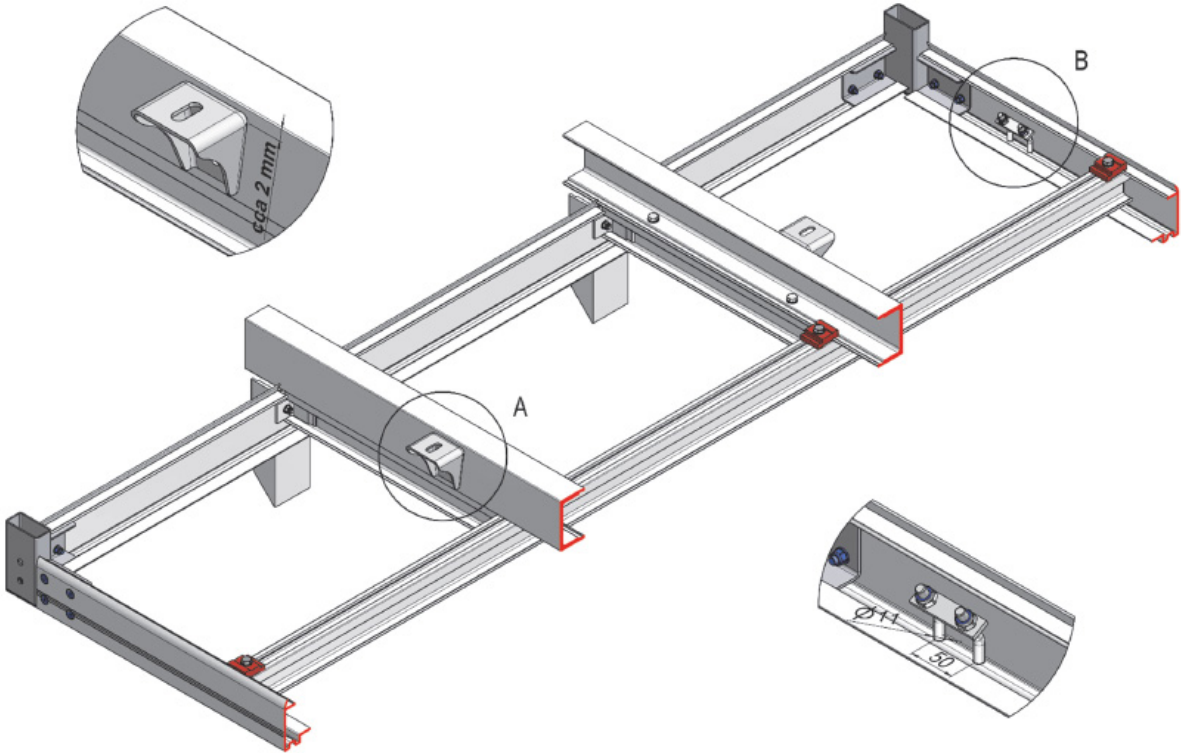

**4 2. Installation of front and rear columns (non-lifting) to corners 80x40
(Type 0433 27x.xxx)**

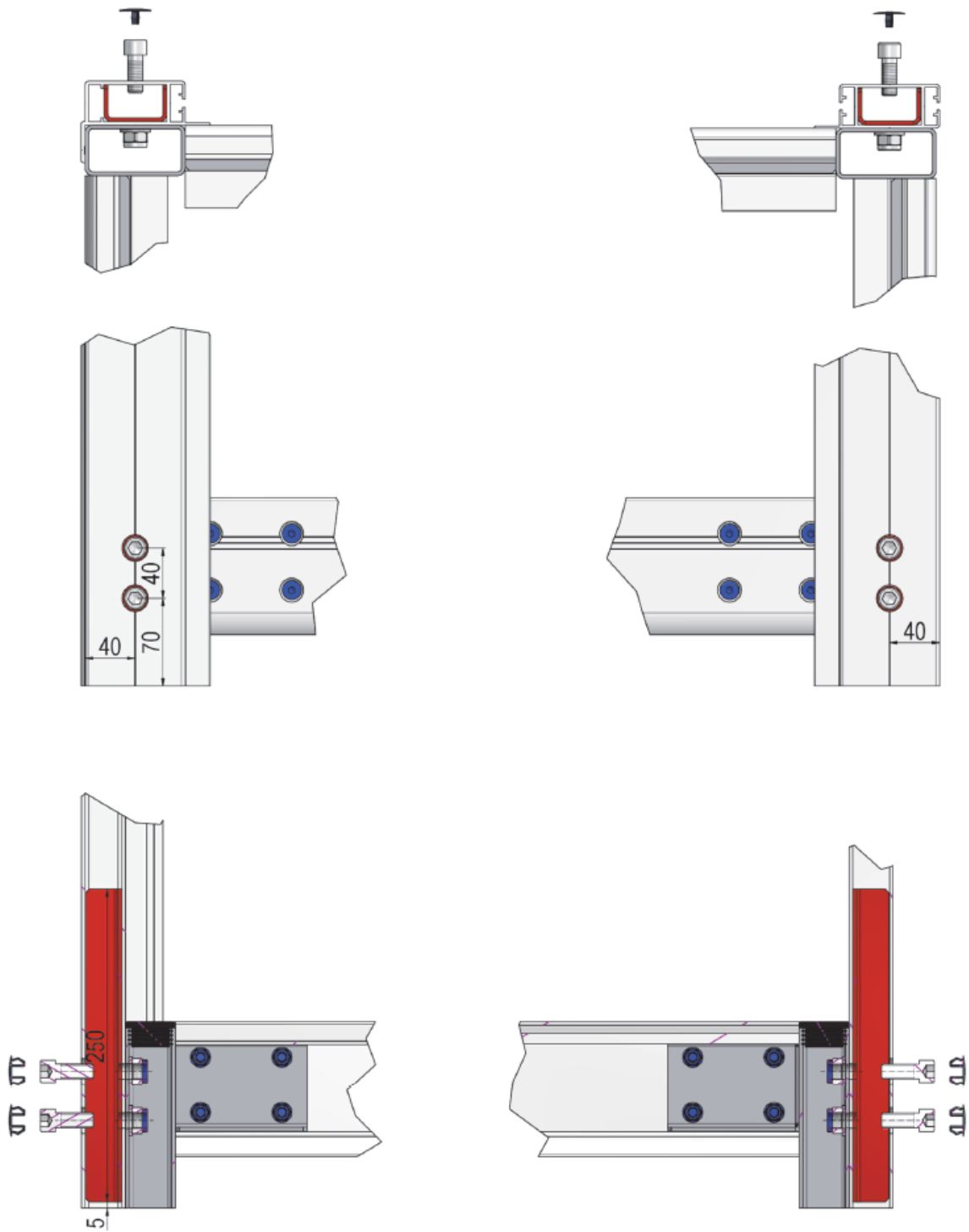

4 3. Installation of lifting columns to corners 80x40

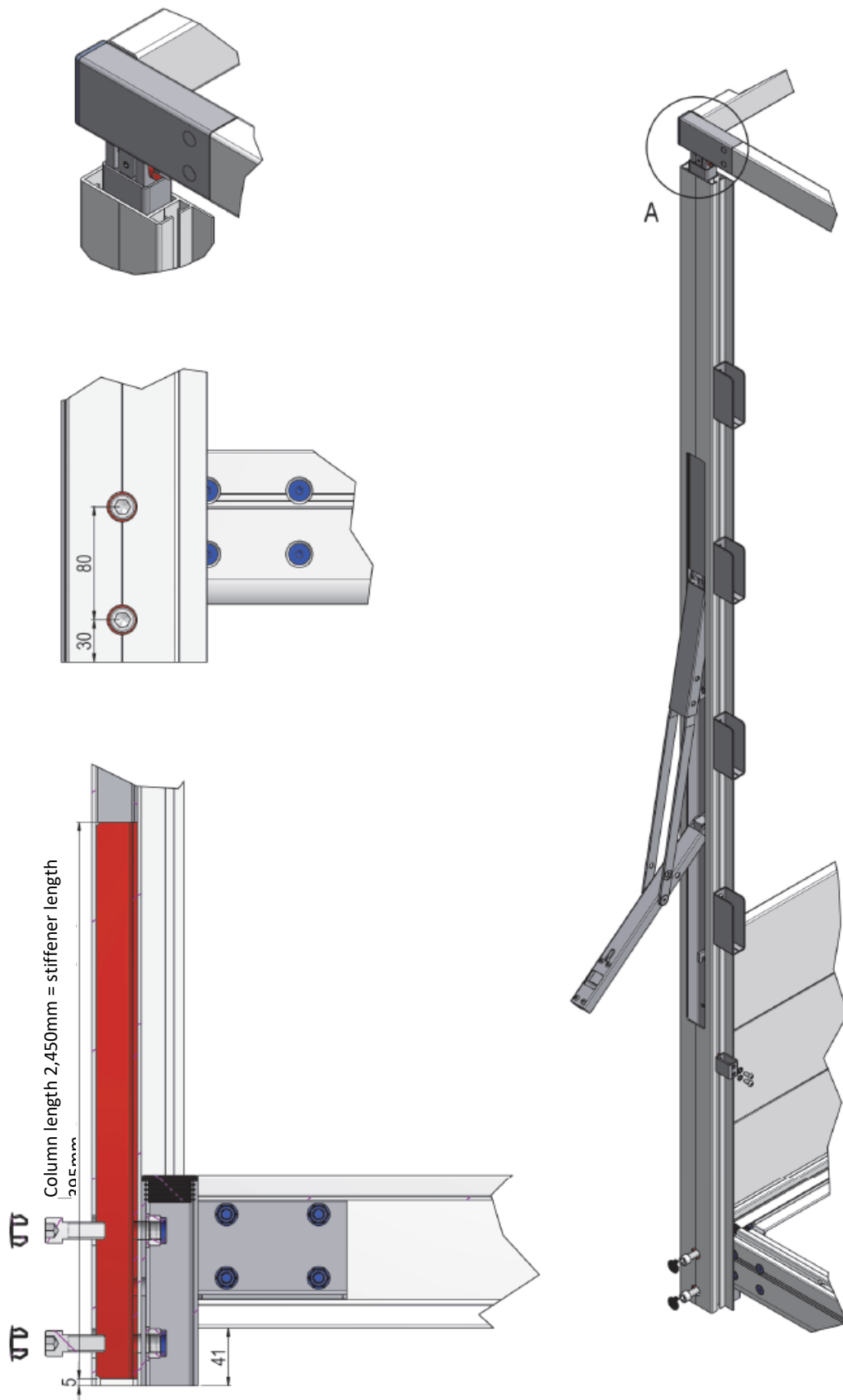

4 4. Installation of the central column

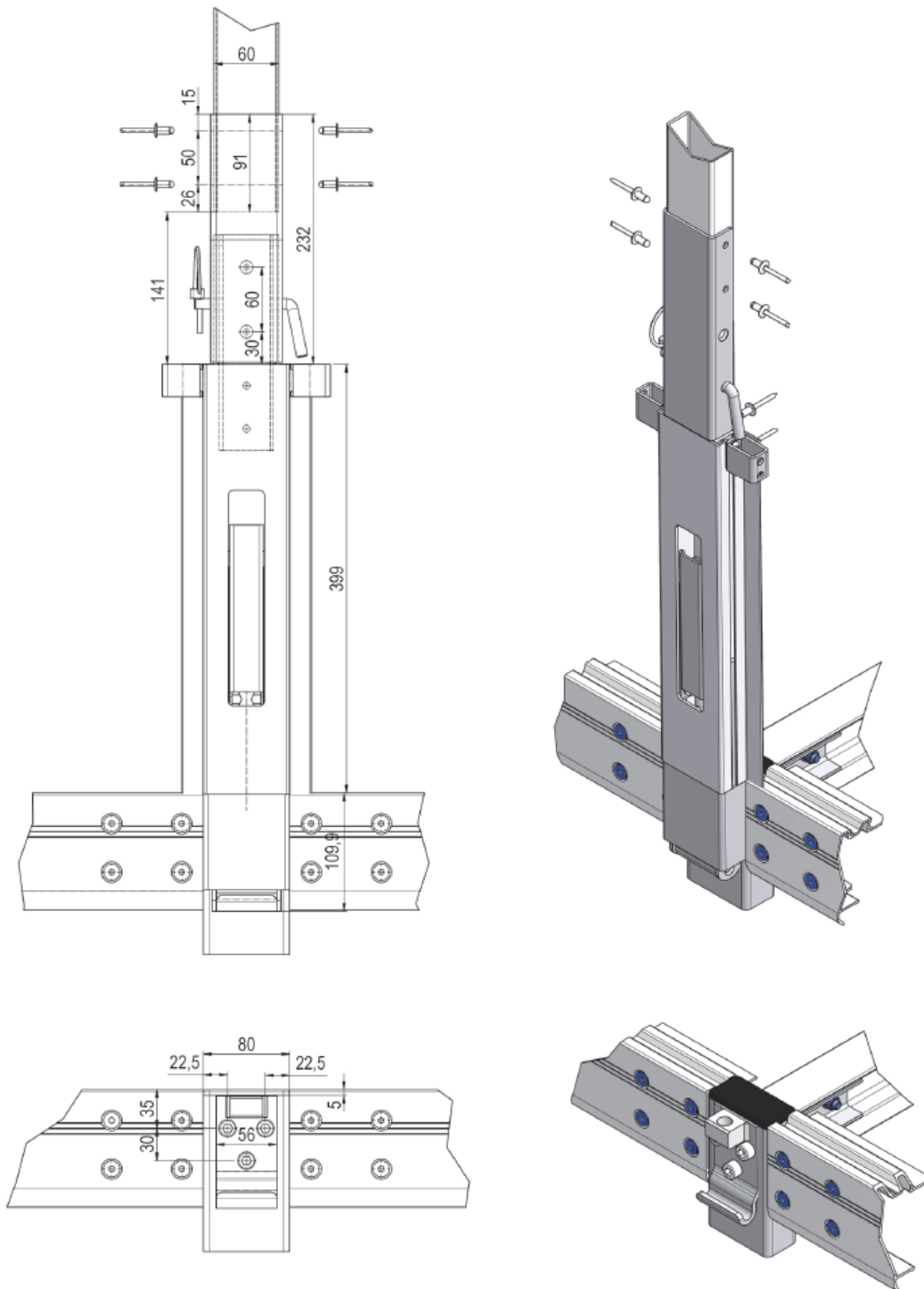

4 5. Installation of the front face

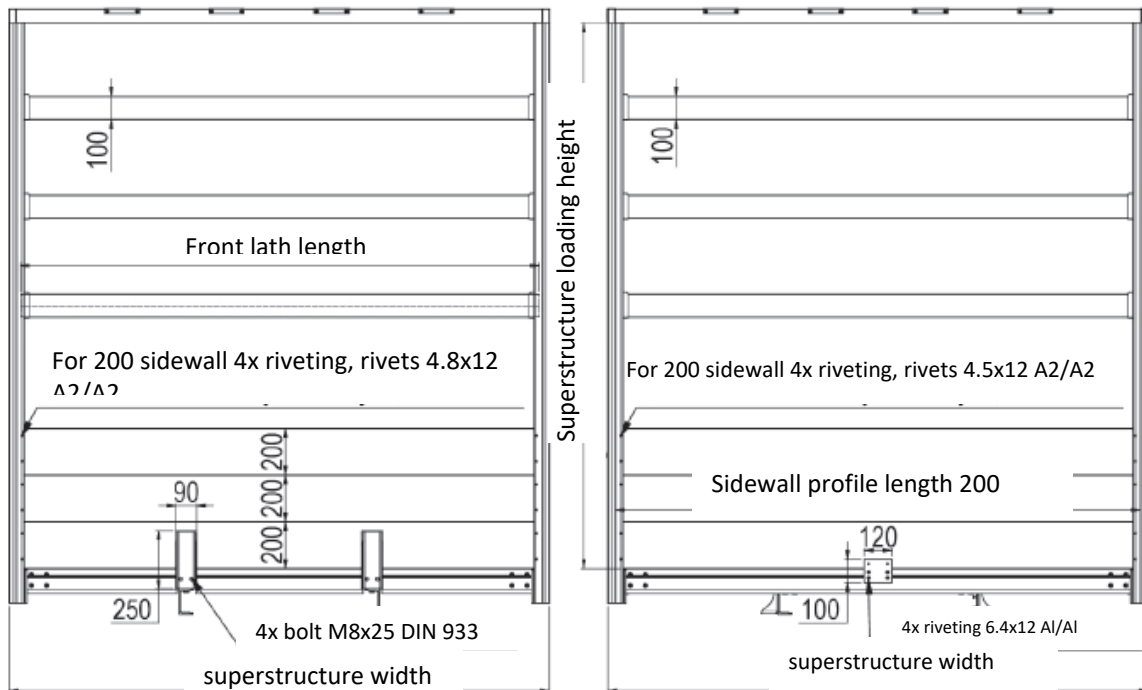

Column length (DS) = Side loading height (BV) + 150

Front hollow profile (JZ) = Superstructure width - 2x30 - 2

Platform width (ŠP) = Platform width - 2x35

Front lath length (DLp) = Superstructure width - 80

Length of the front sidewall profile 200 = Superstructure width - 2x35 - 2

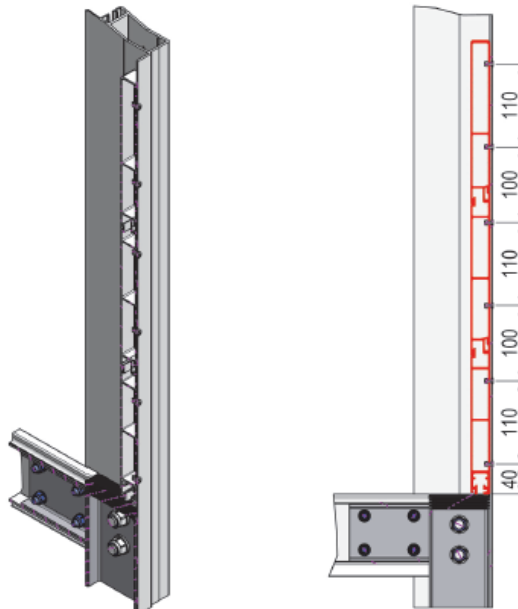

4 6. Installation of sidewalls and pockets for lathes

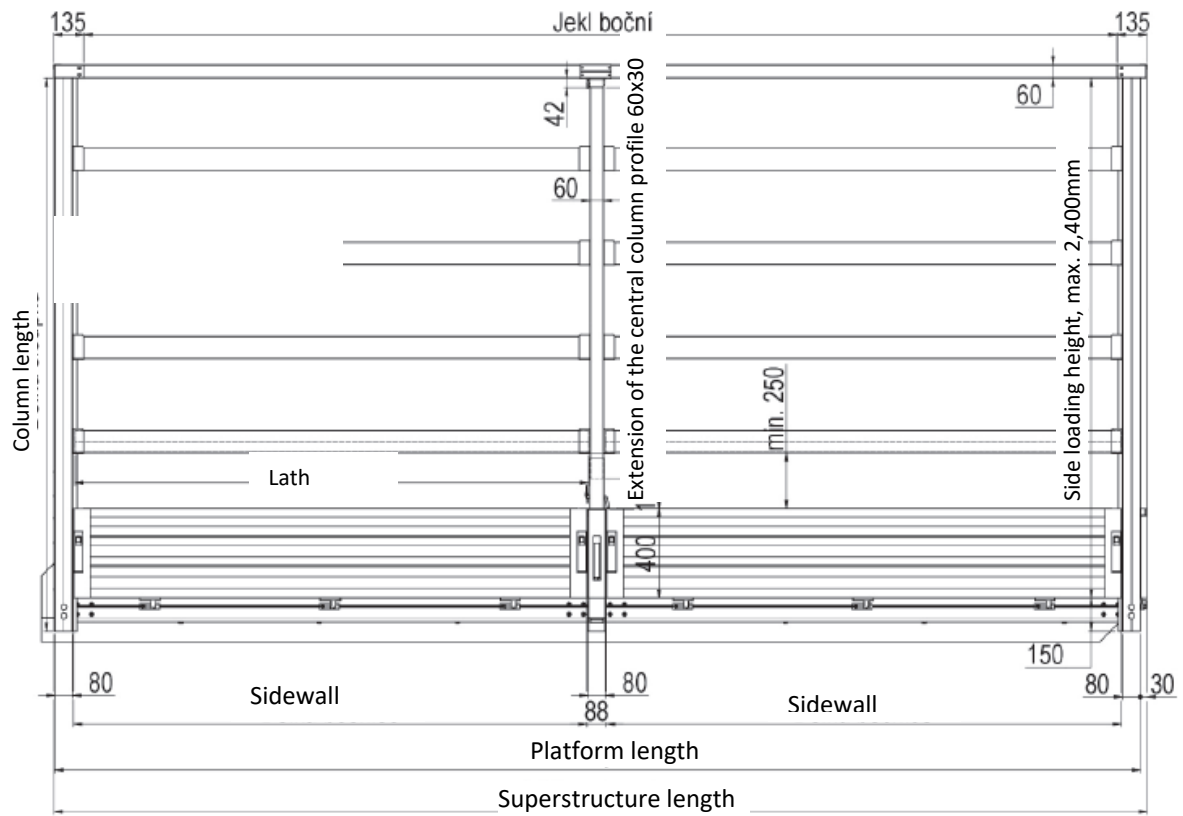

Column length (DS) = Side loading height (BV) + 150

Side hollow profile (JB) = Superstructure length - 2x135 - 2

Central column extension (SS) = BV - Sidewall (400) - 182

Platform length (DP) = Superstructure length - 35

Loading area (LP) = Platform length - 25

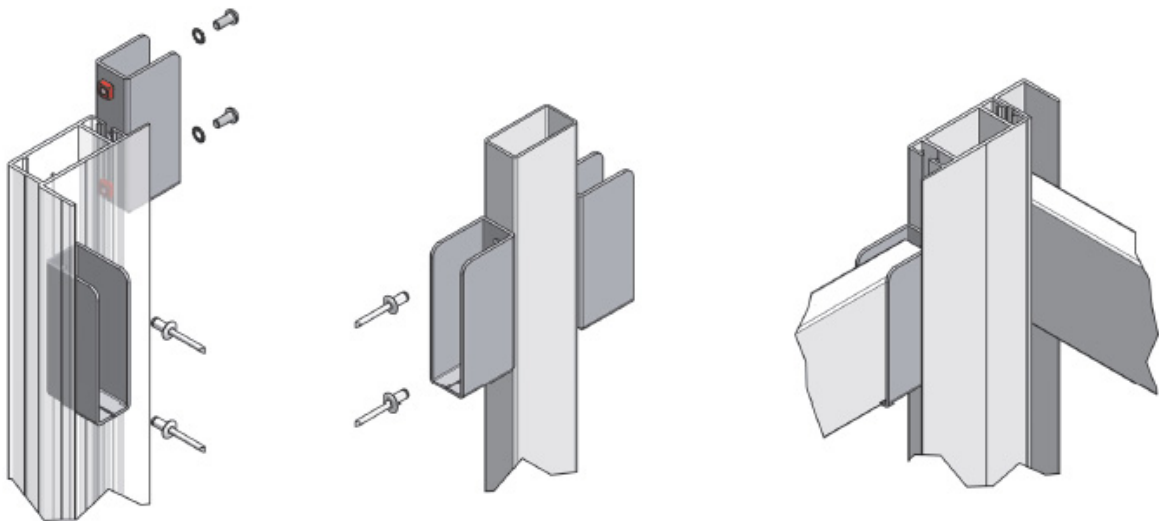

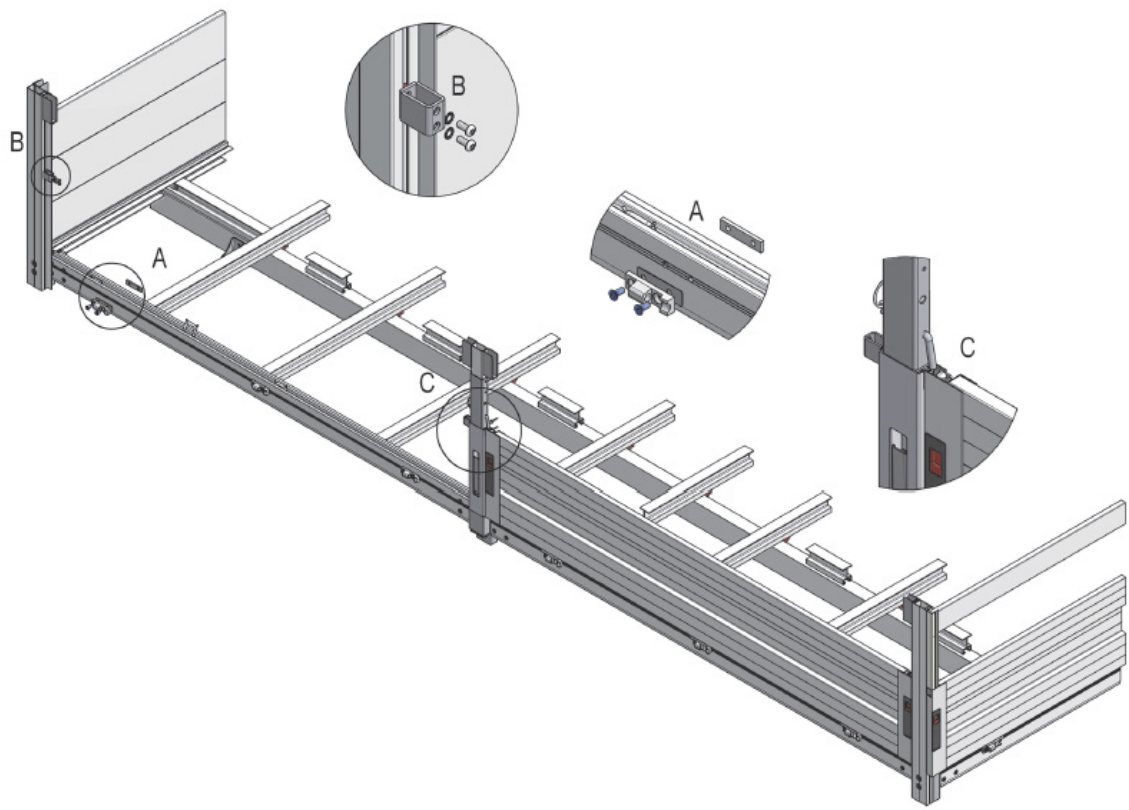

4 7. Installation of the rear face and lathes

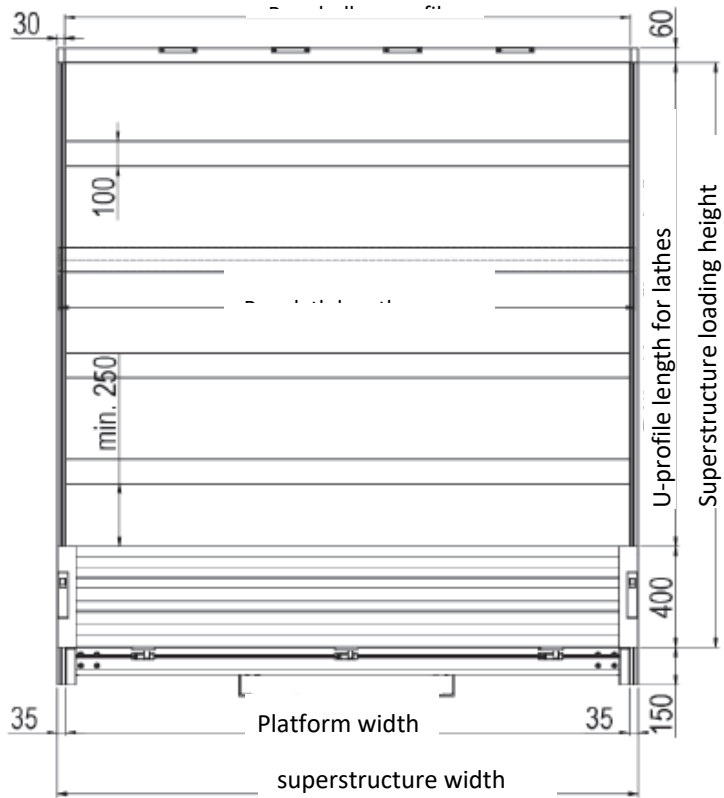

$\text{Column length (DS)} = \text{Side loading height (BV)} + 150$
 $\text{Rear hollow profile (JZ)} = \text{Superstructure width} - 2 \times 30 - 2$
 $\text{Platform width (ŠP)} = \text{Platform superstructure} - 2 \times 35$
 $\text{U-profile length (DUp)} = \text{DS} - \text{Sidewall (400)} - 150 - 5$
 $\text{Rear lath length (DLz)} = \text{Superstructure width} - 10$

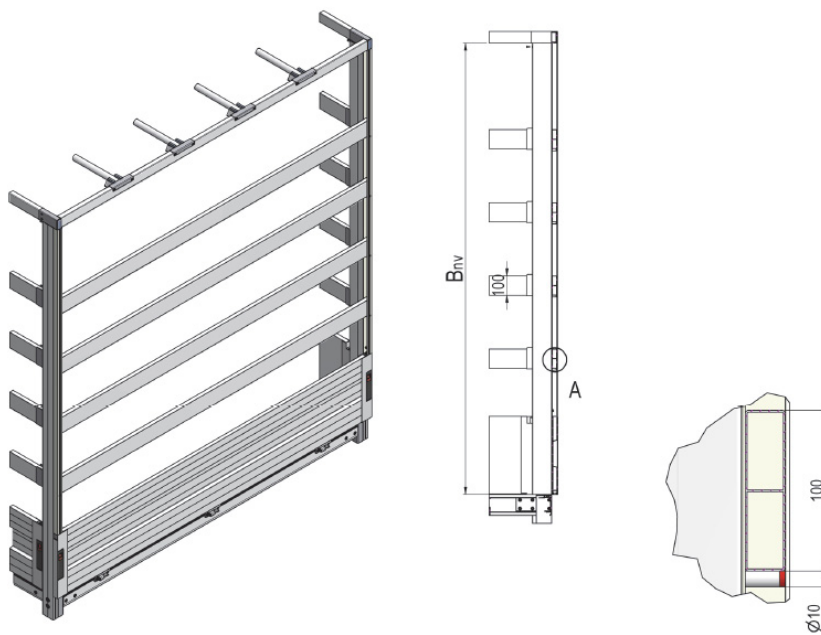

48. Installation of roof parts

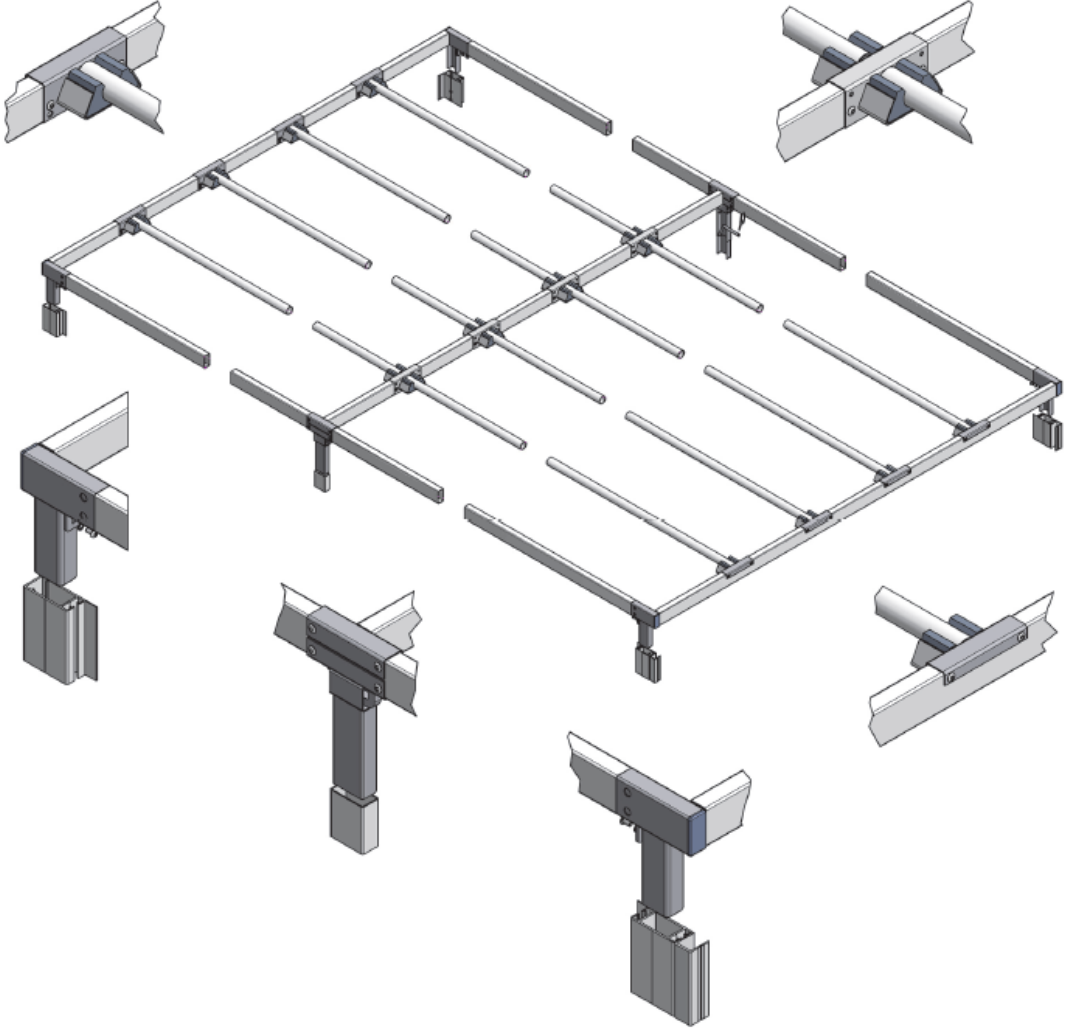
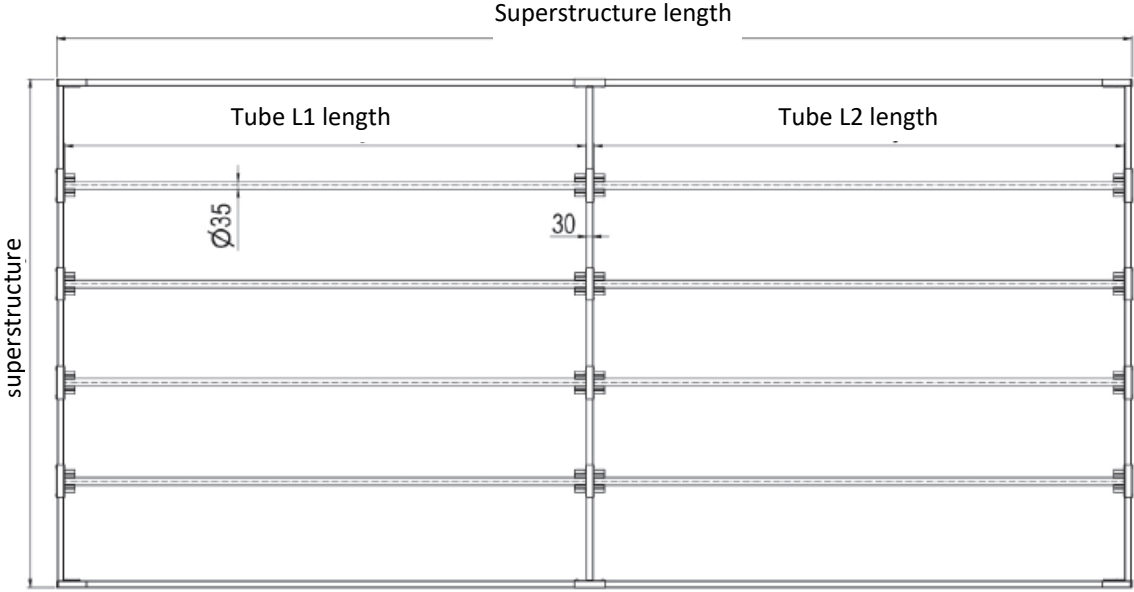

49. Installation of side folding

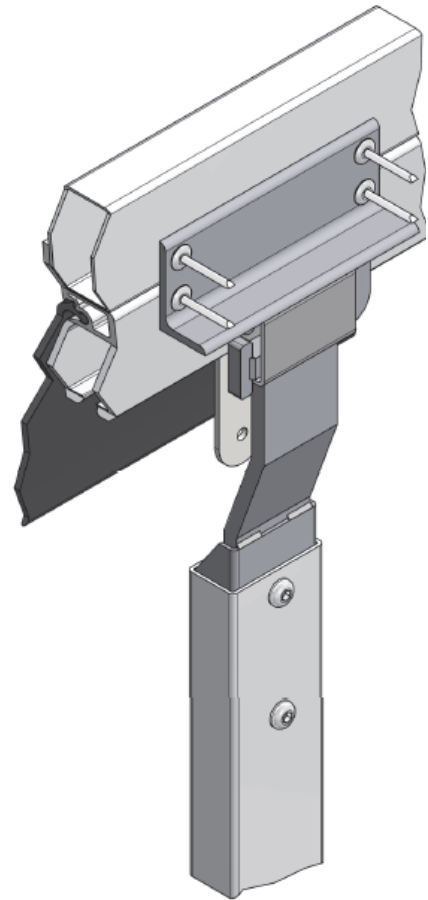
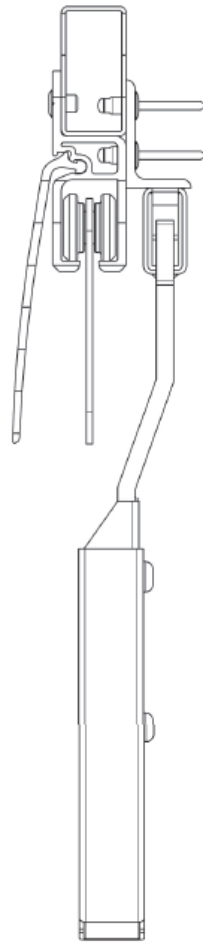
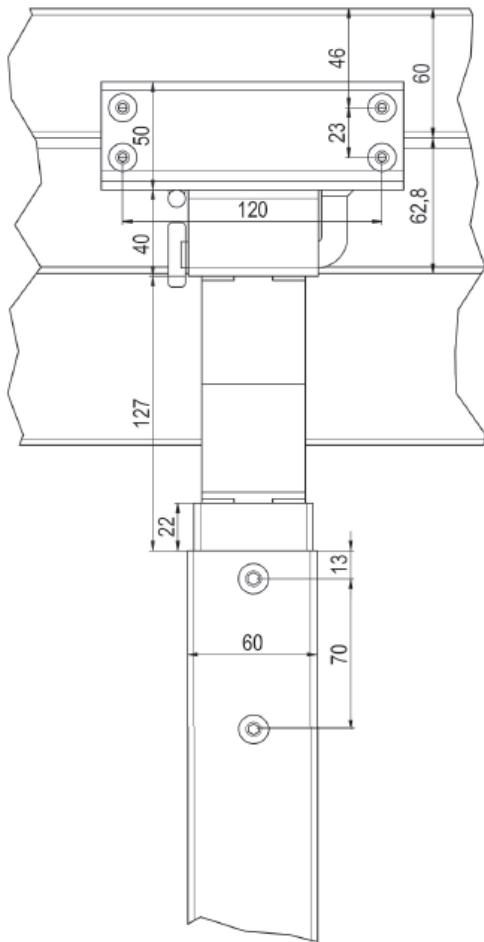

4.10. Installation of the gate

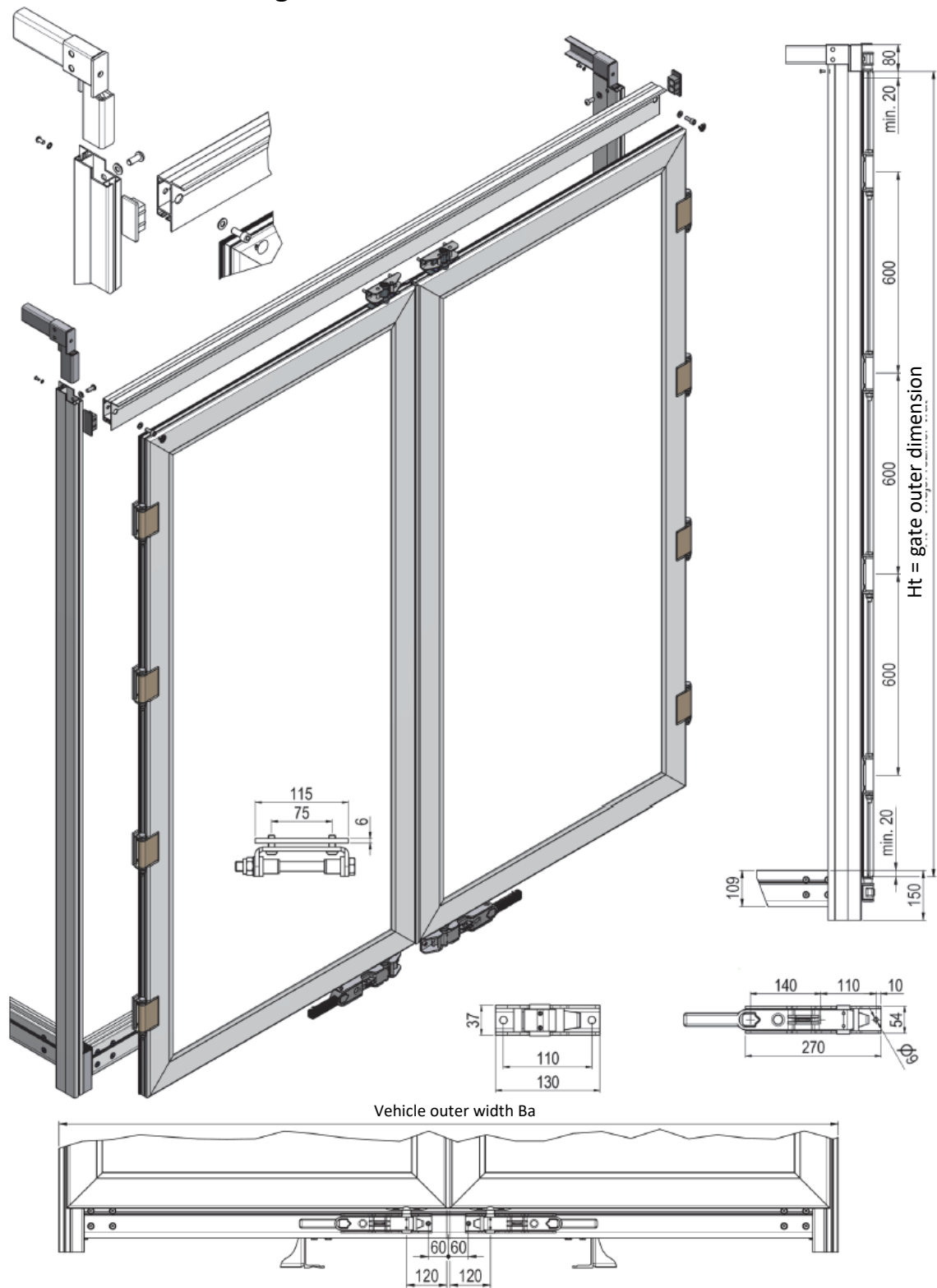

Warranty and spare parts

Our parts are covered with a 24-month warranty according to the law, i.e. from the delivery date. The warranty covers any faults and failures of our parts and structures. The warranty relates to replacement of parts considered as faulty. The warranty is rejected in case when the purchaser or any third party modifies or repairs the delivered goods without prior consent of our company or in case of improper use or bad maintenance.

We recommend to use canvas with specific weight at least 900 g/m² for our superstructures.

Note

The manufacturer reserves the right to make changes in the technical documentation and in the structure or accessories of Versus Omega. These parts were tested in view of their safety and functionality. Versus Omega is not responsible for any damage or injury caused by use of non-original spare parts and accessories.

Delivery and handover of spare parts and accessories provides:

TRANS-TECHNIK spol. .s.r.o., Tyršova 1146, 664 42 Modřice

Manual for ordering, installation and use of TT gate

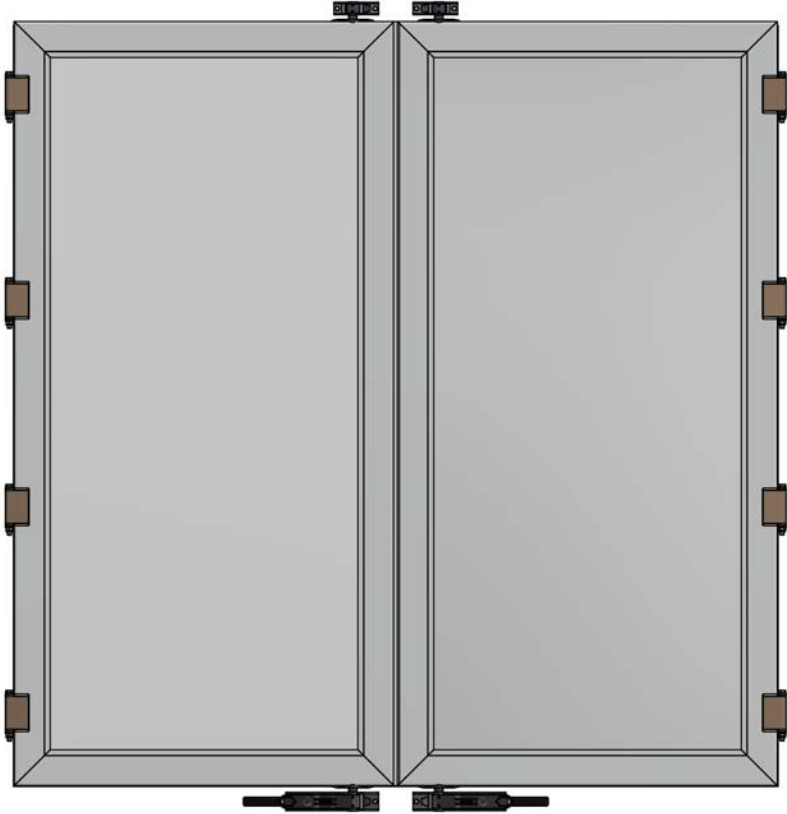

Division of gates, designs and basic dimensions for ordering of gates.

Rear gate can be in the following designs: - double-leaf - double-closure - four-closure
 - four-leaf

- the closures are outer or with flushed closures upon request.
 - gate material: Al natural - Al anodized - Al varnished - Al frame + panel.

Rear gate made of Al profiles with sealing along perimeter and rubber sealing across the centre.

Surface natural and varnished - gate profiles and panels are welded in corners on both sides + Al panels welded from inside (at the top, in the centre and at the bottom).

Designs with anodized surfaces and panels - gate welded in corners from inside. The design with anodized surfaces - the filling panels are welded from inside (at the top, in the centre and at the bottom). The gate panels are glued in the frame profile from outside.

The hinges are made of steel, standardly screwed; also available with welding on or Al riveting (natural or anodized) hinges.

This gate design guarantees high strength, stiffness and therefore long lifespan.

Dimensions for ordering of gates:

When ordering gates, specify dimensions: **Ba x Ht (mm) = (Vehicle outer width x gate height).**

Recommended overlap of the frame and upper portal = 25mm (min. 20mm), see the picture below.

Warning: The gate is provided with a label in its lower corner for easy identification.

**Double-leaf gate
 basic dimensions**

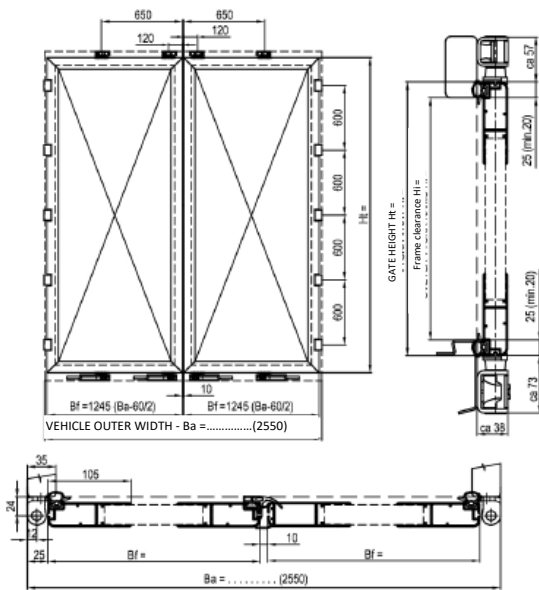

**Four-leaf gate
 basic dimensions**

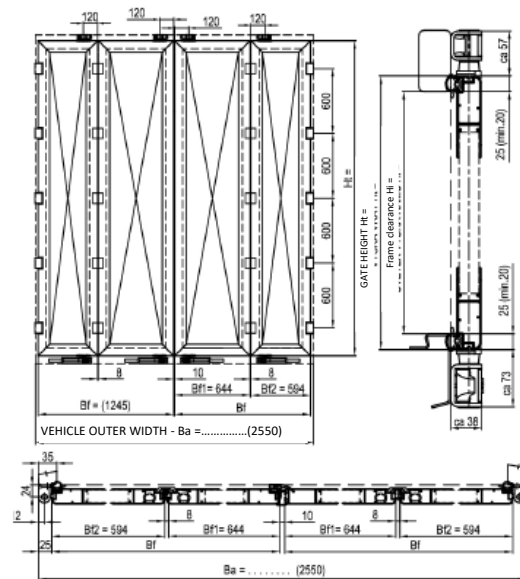

VEHICLE OUTER WIDTH - Ba =	VNĚJŠÍ ŠÍŘKA VOZIDLA – Ba =
GATE HEIGHT Ht =	VÝŠKA VRAT Ht =
Frame clearance Hi =	SVĚTLÁ VÝŠKA RÁMU Hi =

Gate installation - main principles:

Thickness of the column for installation of a gate min. 35mm (due to function of the sealing).

1. Spacing of the hinges is 600mm. Gate shall be located so that the upper and lower overlap of the frame (portal) is min. 20mm, recommended 25mm.

The hinges (welded on, screwed) shall be located so the hinge outer edge is aligned with the outer edge of the column. The hinge "recess" should face to the superstructure outer dimension. See the picture.

Screwed closure: each hinge is fixed using two M8 bolts, strength 8.8.

Welded on hinges: the weld shall be located in the "recessed" part of the hinge, on its outer side (at the bend).

Riveted hinge should be fixed over the column corner by rivets dia. 6,4 x length (acc. to the column wall thickness).

The way of riveting: 1 rivet in the hinge centre, 1 rivet above and under the hinge; applies for each hinge.

ATTENTION!! In case of steel (screwed and welding on) hinges do not tighten the screw M12x140. Tightening - lamping - of the gate joint causes bad causes bad function of the hinge and may lead to sweeping and damage to the sealing.

2. Check the so-called pusher for its damage or knocking off after installation or due to improper use; this component has to protect sealing against sweeping, so sealing of the gate against water in the loading area. The pusher can be installed or replaced easily in case of its loss or damage.

3. We recommend to install a drip mould over each gate to prevent flowing of water from the roof onto the gate.

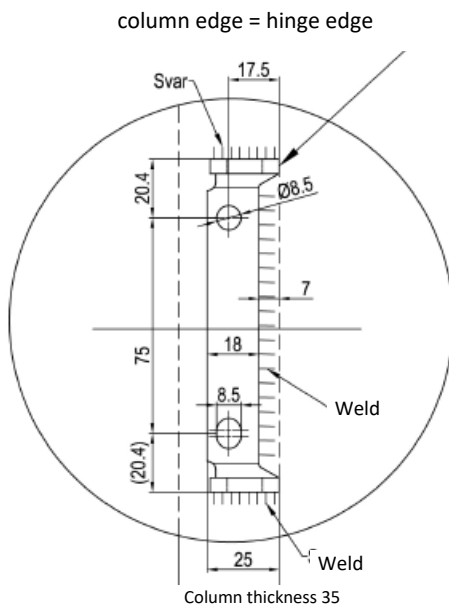

VEHICLE OUTER WIDTH Ba



Use of gates









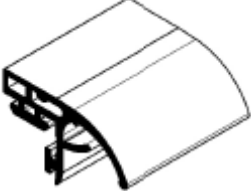
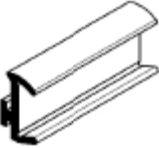

1. **!!! The gate shall be braced diagonally during operation - the journey. !!!!**

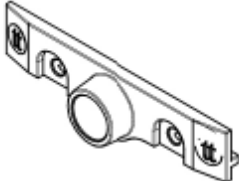

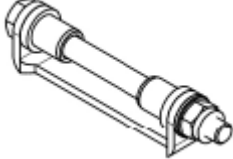
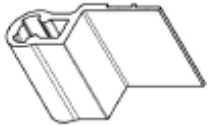

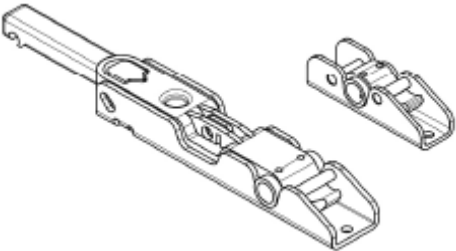
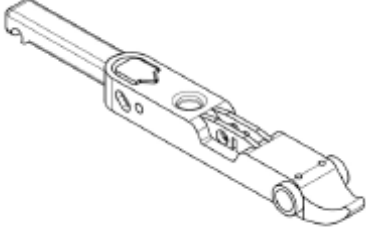
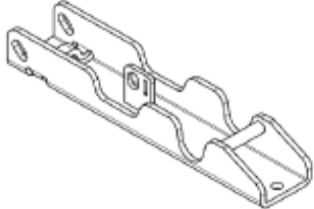
2. **The gate shall be secured i open position using the gate bracket.**
 - do not drive with open gate.
 - . before the journey check whether the upper and lower closures are in closed positions.
 - secure the load against any displacement. The load shall not be in contact with the gate.
 - . Check presence of the gate pusher (located at the gate bottom corner).

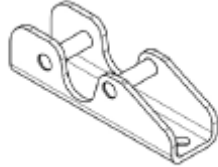
Basic spare parts for gates

TT-no.	Description	Sketch
0512 026.000	Peripheral sealing	
0512 027.000	Central sealing 2K	
0512 028.000	Central sealing 4K	
0512 032.100	Pusher	
0512 030.000	Hinge 2K sleeve	
0512 034.000	Guide	
0512 050.000	Bolted gate hinge	
0512 053.000	Welding on gate hinge	
0512 019.xxx 0512 020.xxx	Welding on gate hinge Al natural Al anodized	

TT-no.	Description	Sketch
0512 035.000	Gate closure 18mm, complete	
0512 035.110	Lower closure lever	
0512 035.120	Closure lever counterpiece	
0512 035.210	Upper closure finger	
0512 035.220	Upper closure counterpiece	
0512 039.000.	Closure rod 18mm - 3,300mm	

TT-no.	Description	Sketch
0991 041.204	Clamping set, strip, width 35mm	
0911 001.100	Anchoring lug with shackle 750kg, galvanised	
2111 464.165	Rivet 6.4x16 S = 5.5-8.5mm; used in the upper part of the column	
2111 464.181	Rivet 6.4x18 S = 9-12mm Used in the lower part of the column in the chamber with the stiffener	